

Part No. 060409-10, Rev. P
July 2024

OmniSwitch 9900 Series Hardware Users Guide

Alcatel·Lucent 
Enterprise

www.al-enterprise.com

This user guide documents OmniSwitch 9900 Series hardware, including chassis and associated components. The specifications described in this guide are subject to change without notice.

The Alcatel-Lucent name and logo are trademarks of Nokia used under license by ALE. To view other trademarks used by affiliated companies of ALE Holding, visit: www.al-enterprise.com/en/legal/trademarks-copyright. All other trademarks are the property of their respective owners. The information presented is subject to change without notice. Neither ALE Holding nor any of its affiliates assumes any responsibility for inaccuracies contained herein. © Copyright 2023 ALE International, ALE USA Inc. All rights reserved in all countries.



ALE USA Inc.
2000 Corporate Center Drive
Thousand Oaks, CA 91320
(818) 880-3500

Service & Support Contact Information

North America: 800-995-2696
Latin America: 877-919-9526
EMEA: +800 00200100 (Toll Free) or +1(650)385-2193
Asia Pacific: +65 6240 8484
Web: myportal.al-enterprise.com
Email: ale.welcomecenter@al-enterprise.com

Contents

	About This Guide	1
	Related Documentation	1-1
	Customer Support	1-1
Chapter 1	Chassis and Power	1-2
	OmniSwitch 9907 Series	1-2
	OmniSwitch 9912 Series	1-8
	Chassis Management	1-14
	Switch Fabric	1-18
	NI Modules	1-20
	NI Module LEDs	1-24
	Fan Trays	1-25
	Power Supplies	1-26
	DC Power Supply Connection	1-27
Chapter 2	Getting Started and Installation	1-29
	Getting Started	1-29
	Mounting the Chassis	1-33
	Installing Chassis Components	1-33
	Booting the Switch	1-42
Chapter 3	Power Over Ethernet (PoE)	1-47
	Managing Power over Ethernet (PoE)	1-47
Chapter 4	Removing Chassis Components	1-54
	Removing Chassis Components	1-54
	Removing Modules	1-59
	Hot Swapping	1-60
Appendix A	Regulatory Compliance and Safety Information	1-1

About This Guide

Related Documentation

The following related documents can be found at myportal.al-enterprise.com:

- [OmniSwitch CLI Reference Guide](#)
- [OmniSwitch AOS Switch Management Guide](#)
- [OmniSwitch AOS Network Configuration Guide](#)
- [OmniSwitch AOS Advanced Routing Configuration Guide](#)
- [OmniSwitch AOS Data Center Guide](#)
- [OmniSwitch Transceivers Guide](#)

Product Release Notes

Release Notes can be downloaded from the [Customer Support website](#) (account login required).

Customer Support

Web: myportal.al-enterprise.com

Email: ale.welcomecenter@al-enterprise.com

1 Chassis and Power

OmniSwitch 9907 Series

The Alcatel-Lucent Enterprise OmniSwitch 9907 11 RU modular LAN chassis.

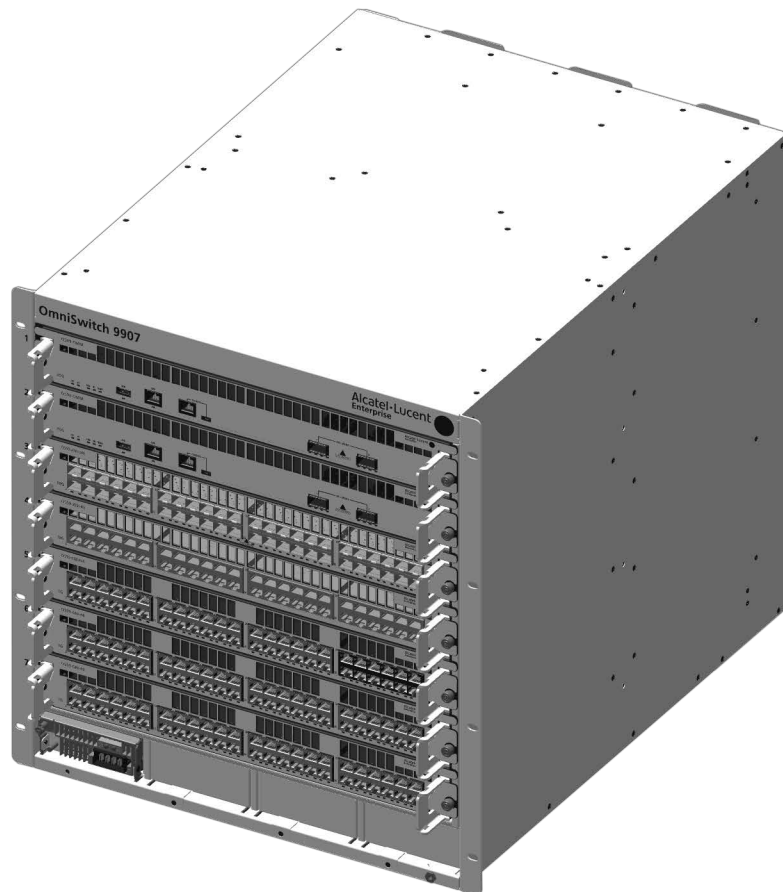

OS9907 Chassis Specifications

Slots	7
Chassis Management Module (CMM) Slots	2
Chassis Fabric Module (CFM) Slots	4 (Slots CFM 3 and CFM 4 are currently inactive and are reserved for future use.)
Network Interface (NI) Slots	5

OS9907 Chassis Specifications	
Fan Trays	3
Power Supplies	4
Rack Unit Dimensions	11 RU
Dimensions (HxWxD)	49.02 x 44.2 x 58.42 cm (19.3 x 17.4 x 23 in)
Weight	32.83 kg (72.24 lb)
Operating Temperature	0°C to 45°C (32°F to 113°F)
Storage Temperature	10°C to 70°C (14°F to 158°F)
Operating and Storage Humidity	10% to 90% (non-condensing)
Altitude	4000m/13,000 feet

Note: Modules are transitioning to ship with aluminum-headed thumbscrews instead of violet color, plastic thumbscrews. The thumbscrews are mechanically identical and only differ in color.

Chassis Front Panel

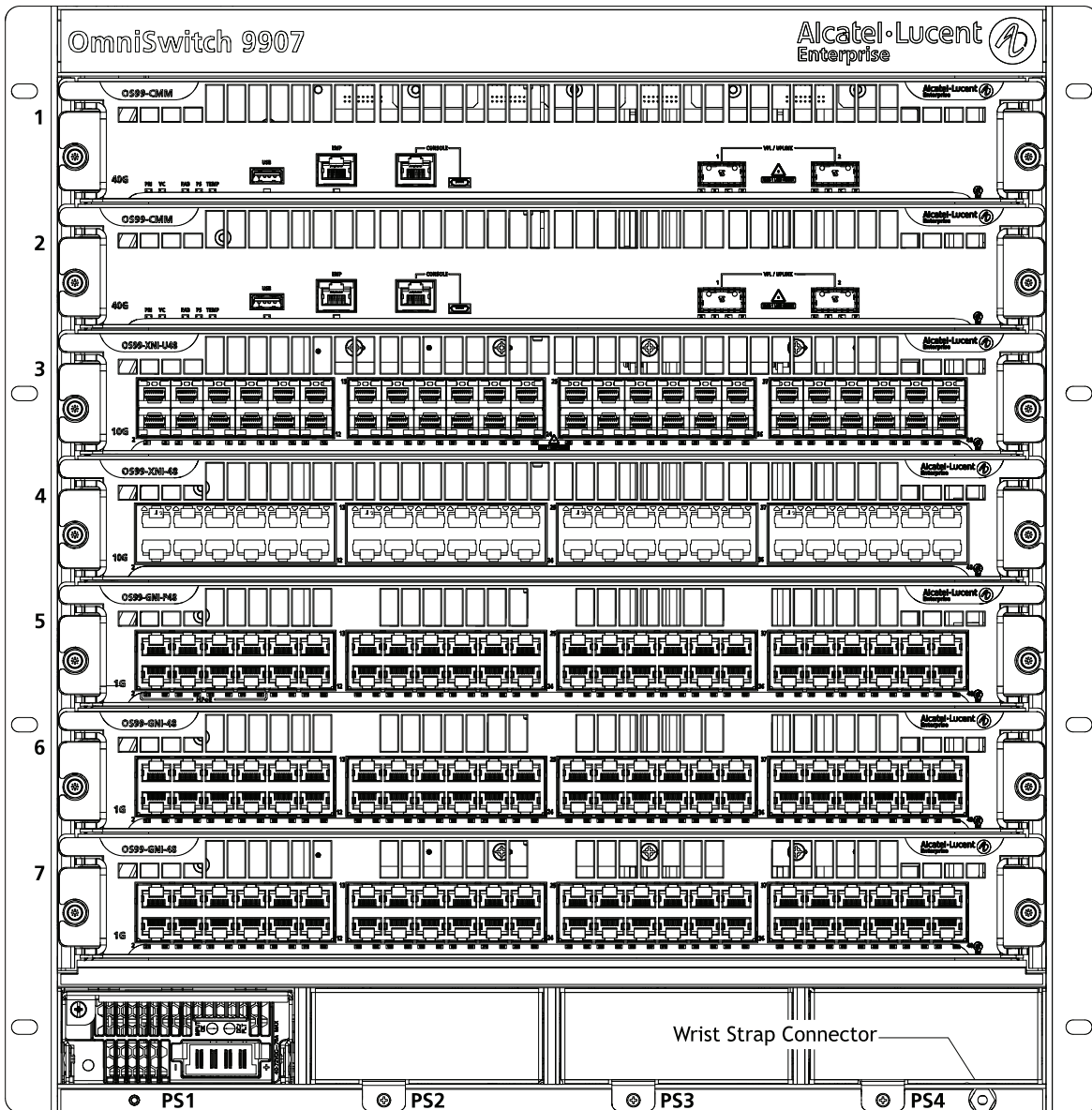

OS9907 Front Panel Components

Slot 1	Supports Chassis Management Module (CMM) only
Slot 2	Supports a CMM (for 1+1 CMM redundancy) or NI module (to maximize port count) Note: When an XNI module (i.e. OS99-XNI-U48) is inserted in slot 2 only the first 8 ports will be active. This is due to the architecture required for slot 2 to have the capability of supporting either a CMM or NI module.
Slots 3 through 7	Support NI modules only

OS9907 Front Panel Components

Slots PS1 through PS4

Support up to four load-sharing chassis power supplies, offering N+1 redundancy

Wrist Strap Grounding Connector

Location shown in diagram above

Chassis Rear Panel

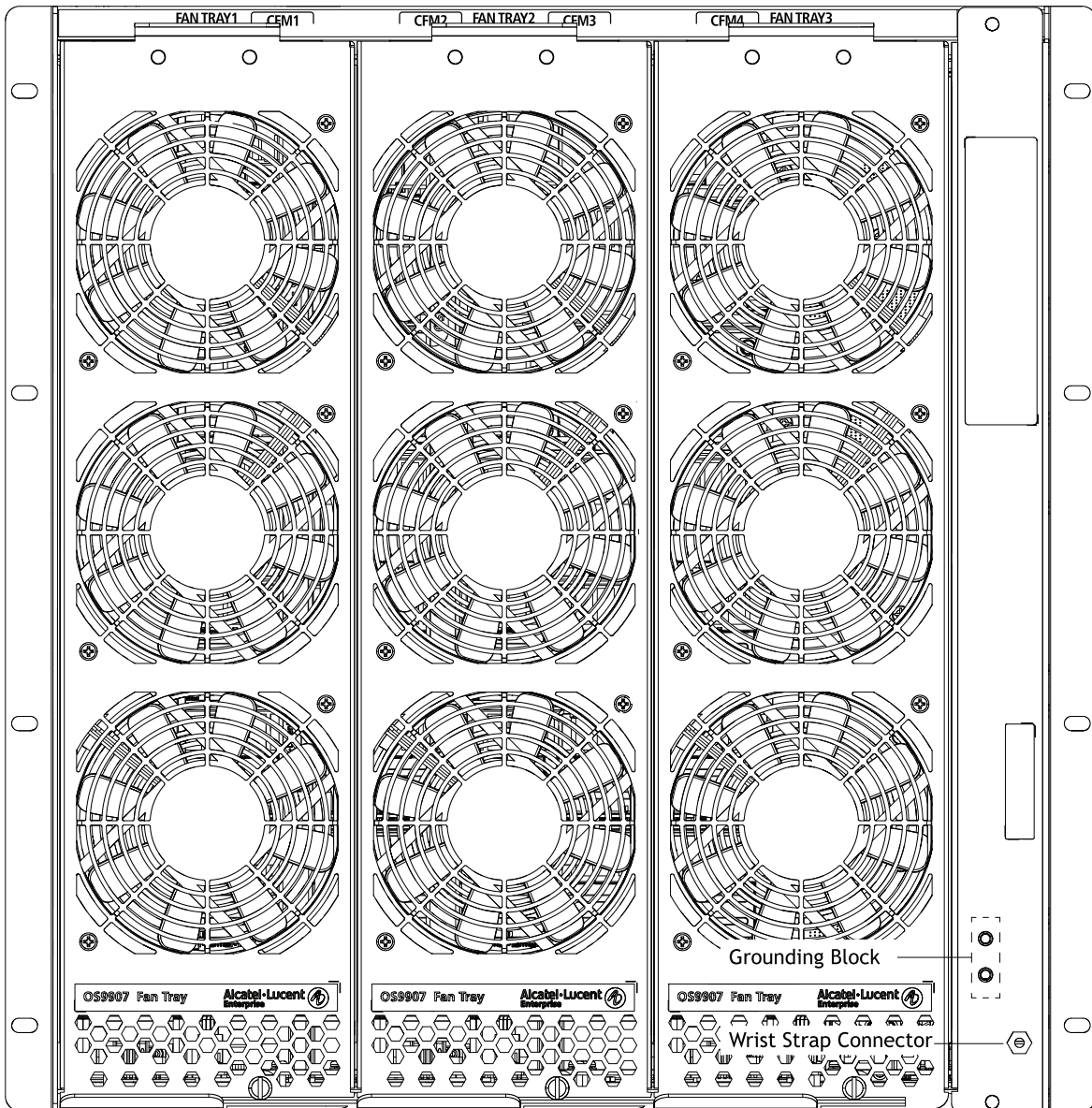

Fan tray slot numbers are printed along the top-rear of the chassis.

OS9907 Rear Panel Components

Fan Tray Slots 1 through 3

Support three fan trays, with three fans per tray for N+1 fan redundancy

Grounding Block

Location shown in diagram above

Wrist Strap Grounding Connector

Location shown in diagram above

Chassis Rear Panel (Fan Trays Removed)

CFMs are located behind the chassis fan trays. To access a CFM, remove the fan tray in front of the module. See [“Removing Fan Trays” on page 4-53](#) for more information.

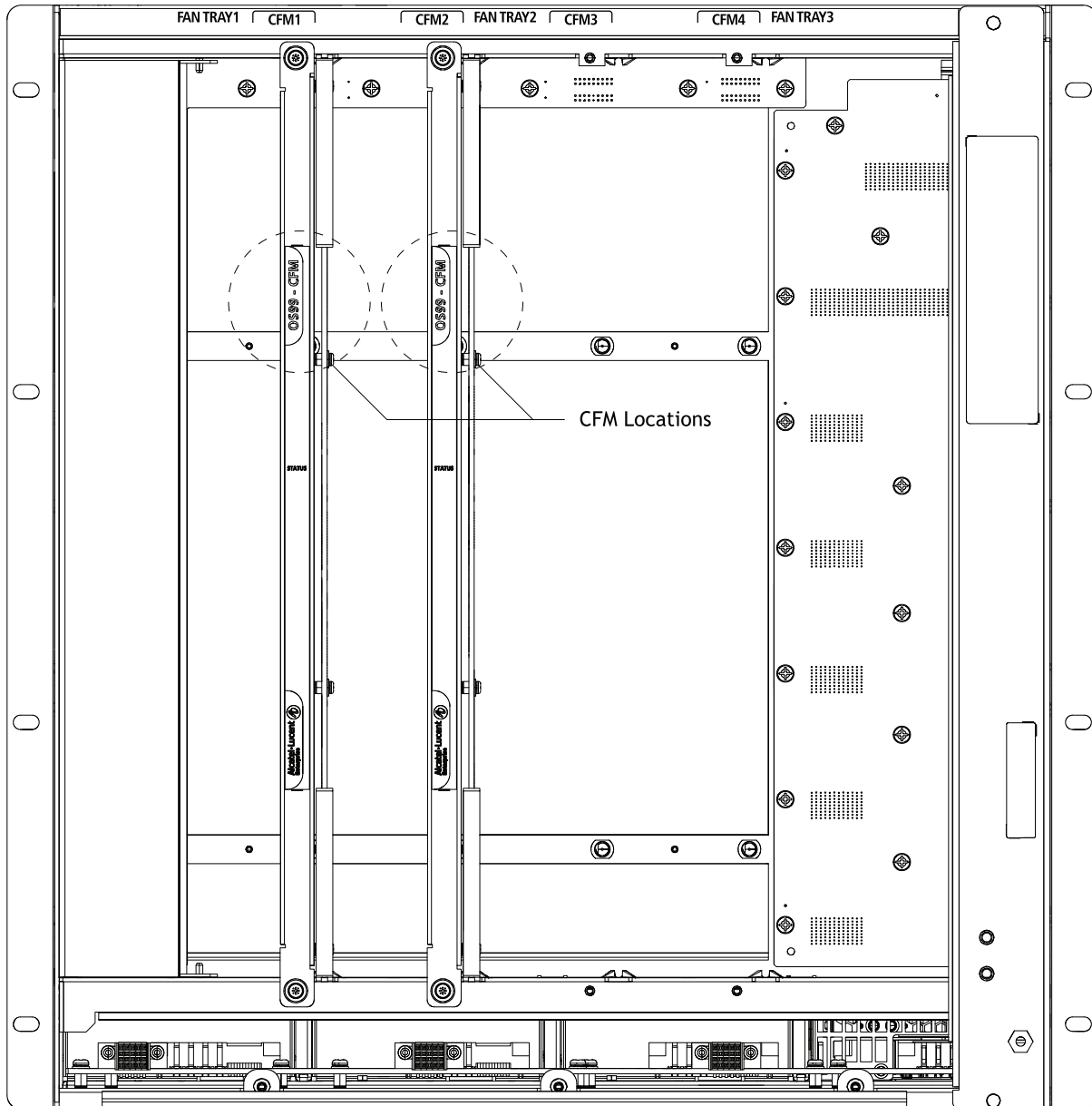

CFM slot numbers are printed along the top-rear of the chassis.

OS9907 CFM Location

Slots CFM1 through CFM4

For CFM module use only. Slots CFM1 and CFM2 are currently supported; slots CFM 3 and CFM 4 are inactive and reserved for future use.

OmniSwitch 9912 Series

The Alcatel-Lucent Enterprise OmniSwitch 9912 17 RU modular LAN chassis.

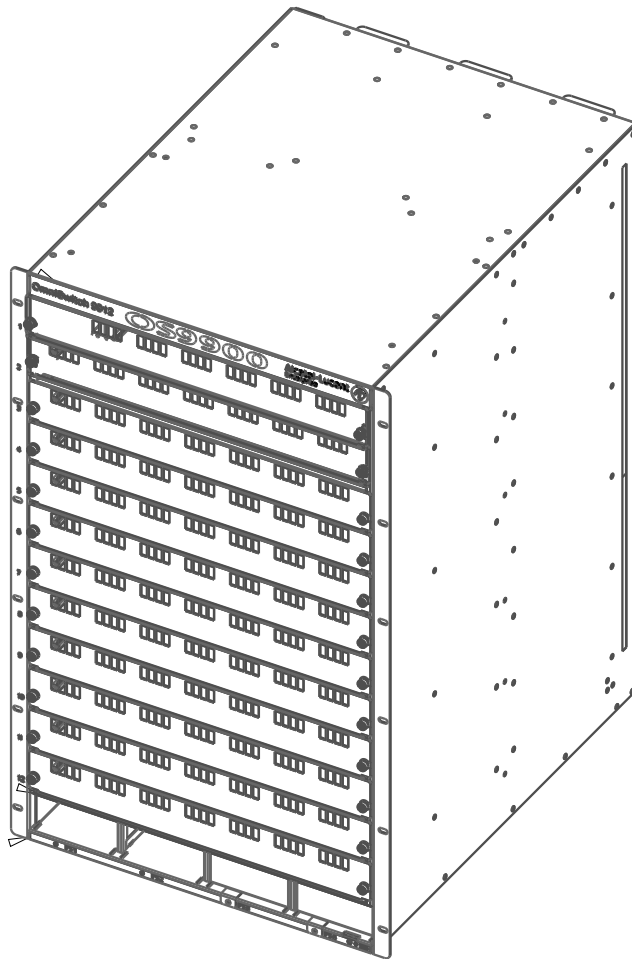

OS9912 Chassis Specifications

Slots	12
Chassis Management Module (CMM) Slots	2
Chassis Fabric Module (CFM) Slots	4 (Slots CFM 3 and CFM 4 are currently inactive and are reserved for future use.)
Network Interface (NI) Slots	10
Fan Trays	3
Power Supplies	4
Rack Unit Dimensions	17 RU
Dimensions (HxWxD)	76.57 x 44.2 x 58.42 cm (30.15 x 17.4 x 23 in)
Weight	64.36 kg (141.9 lb)

OS9912 Chassis Specifications

Operating Temperature	0°C to 45°C (32°F to 113°F)
Storage Temperature	10°C to 70°C (14°F to 158°F)
Operating and Storage Humidity	10% to 90% (non-condensing)
Altitude	4000m/13,000 feet

Note: Modules are transitioning to ship with aluminum-headed thumbscrews instead of violet color, plastic thumbscrews. The thumbscrews are mechanically identical and only differ in color.

Chassis Front Panel

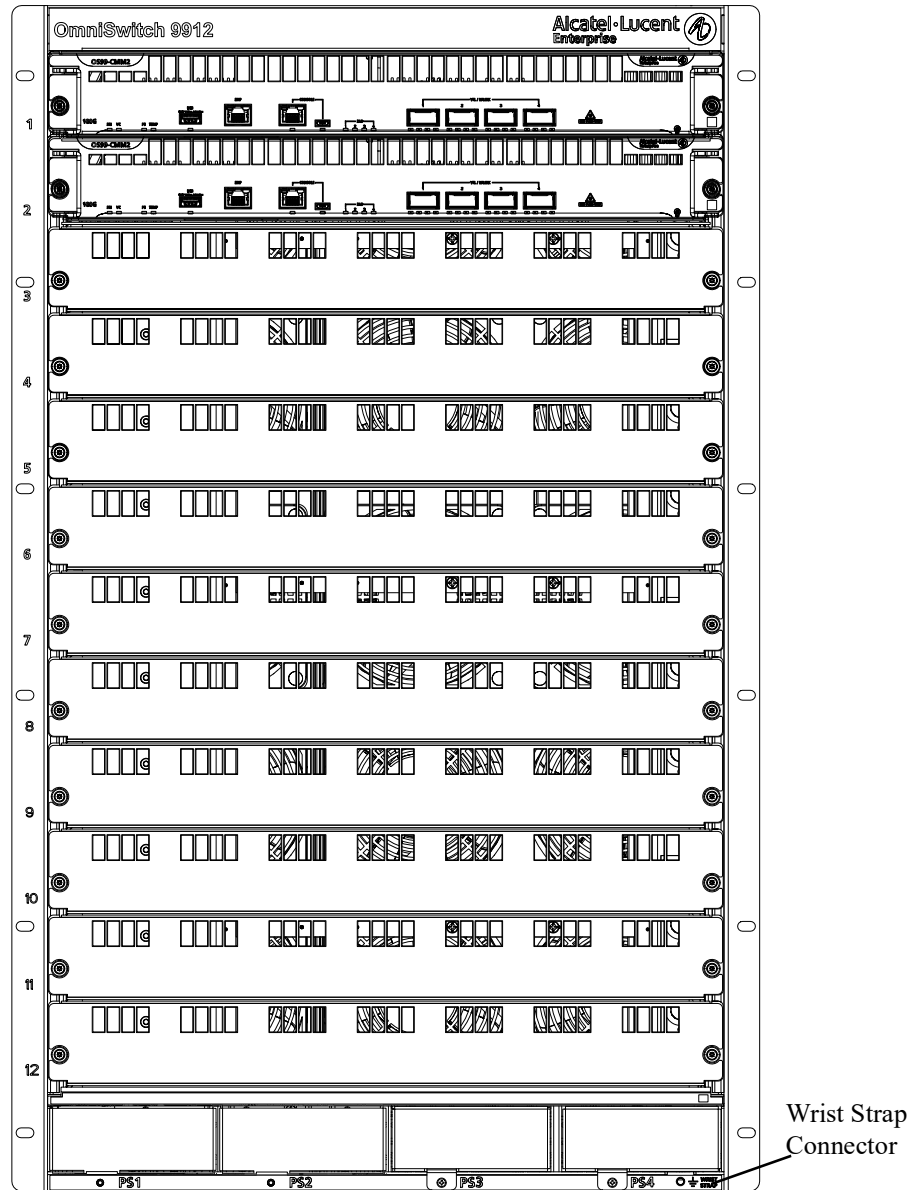

OS9912 Front Panel Components	
Slots 1	Supports Chassis Management Module (CMM) only
Slot 2	Supports Chassis Management Module (CMM) only
Slots 3 through 12	Support NI modules only
Slots PS1 through PS4	Support up to four load-sharing chassis power supplies, offering N+1 redundancy
Wrist Strap Grounding Connector	Location shown in diagram above

Chassis Rear Panel

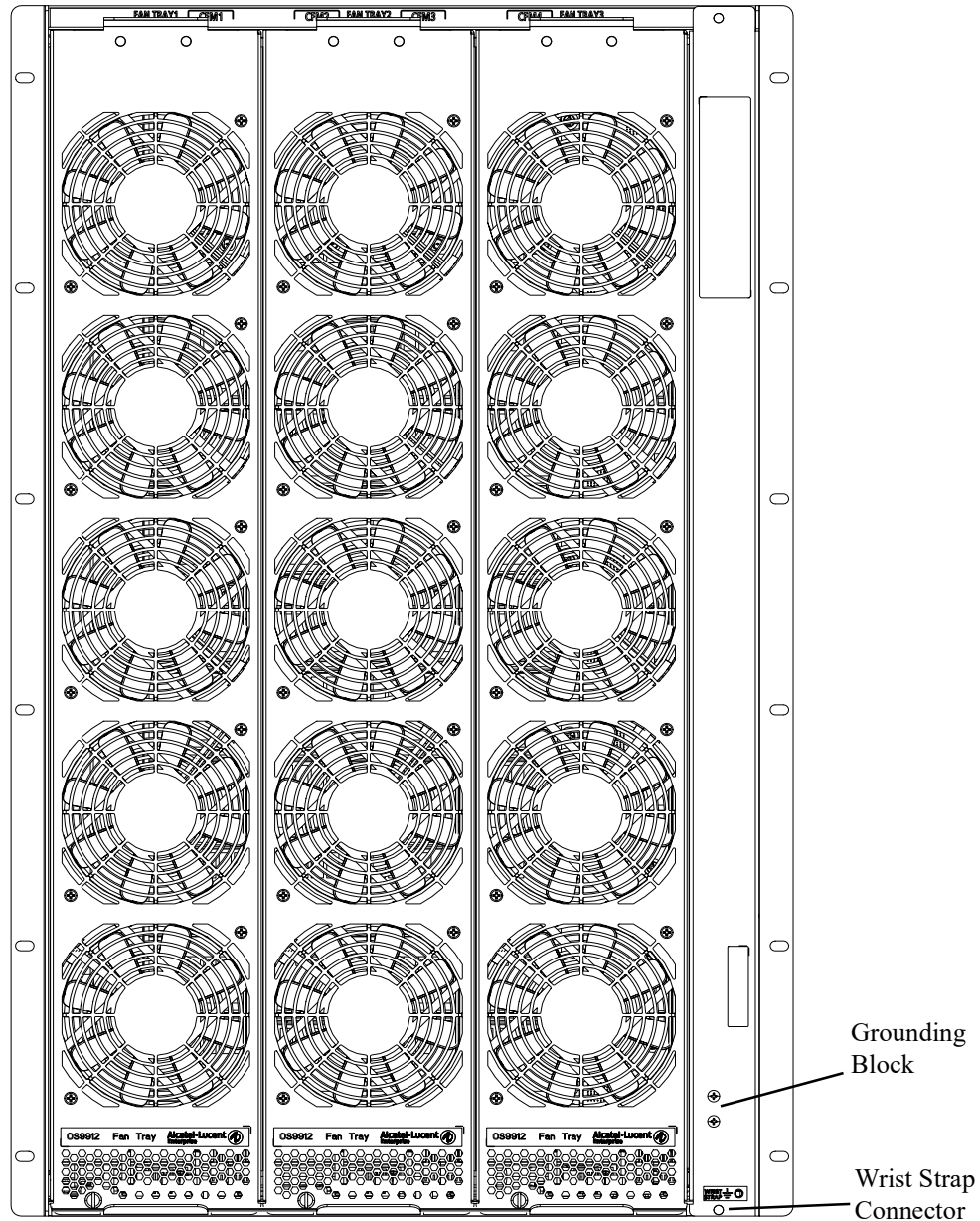

Fan tray slot numbers are printed along the top-rear of the chassis.

OS9912 Rear Panel Components

Fan Tray Slots 1 through 3

Support three fan trays, with five fans per tray for N+1 fan redundancy

Grounding Block

Location shown in diagram above

Wrist Strap Grounding Connector

Location shown in diagram above

Chassis Rear Panel (Fan Trays Removed)

CFMs are located behind the chassis fan trays. To access a CFM, remove the fan tray in front of the module. See [“Removing Fan Trays” on page 4-53](#) for more information.

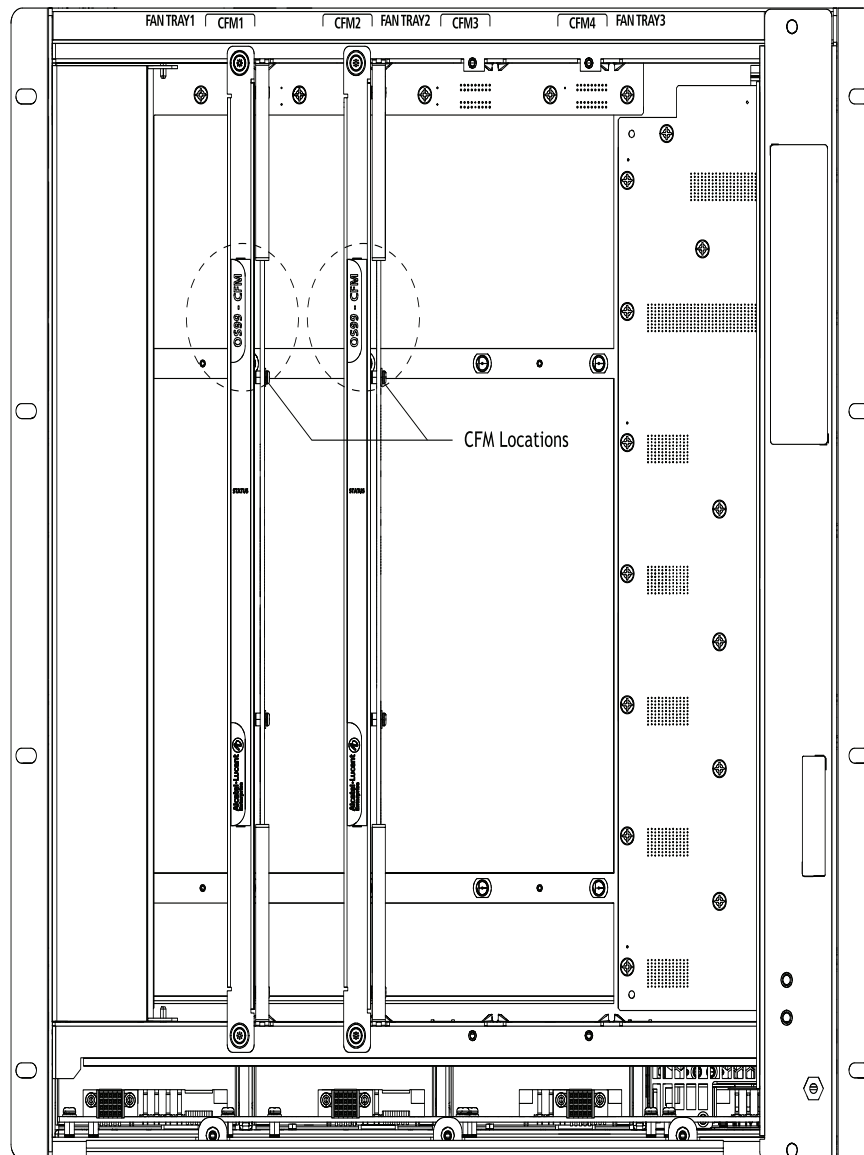

CFM slot numbers are printed along the top-rear of the chassis.

OS9912 CFM Location

Slots CFM1 through CFM4

For CFM module use only. Slots CFM1 and CFM2 are currently supported; slots CFM 3 and CFM 4 are inactive and reserved for future use.

Chassis Management

OS99-CMM

The CMM manages system functions in the chassis. This includes controlling and monitoring NIs, fabric modules (CFMs) and power distribution. The CMM also provides two (2) 40G QSFP+ uplink ports.

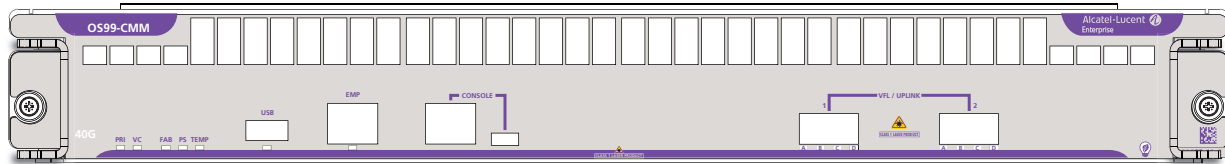

CMM Specifications

Port Types (pictured from left to right)

USB Type A: For storage devices that can download code or save configuration information, such as flash-based pen drives or external hard drives
 EMP (RJ45): 10/100/1000 Base-T with auto-negotiation for out-of-band management (e.g., Telnet connection, diagnostics, downloading software, etc.)
 Console (RJ45): For console or modem
 Console (Micro-USB*): For console or modem
 QSFP+ (Qty 2): 40G QSFP+ uplink ports

Power Consumption

64W

Number of Slots

2 (Slot positions 1 and/or 2. The slot 2 position may be used for an NI module in lieu of a secondary CMM. Note that, when an NI is installed in slot 2, CMM redundancy is not provided.)

Note: Supported on OS9907 chassis only.

***Note.** A driver is required for Micro-USB port operation. For information on downloading the driver, refer to the OmniSwitch AOS Switch Management Guide.

OS99-CMM2

The CMM2 manages system functions in the chassis. This includes controlling and monitoring NIs, fabric modules (CFMs) and power distribution. The CMM also provides four (4) 100G QSFP28 ports.

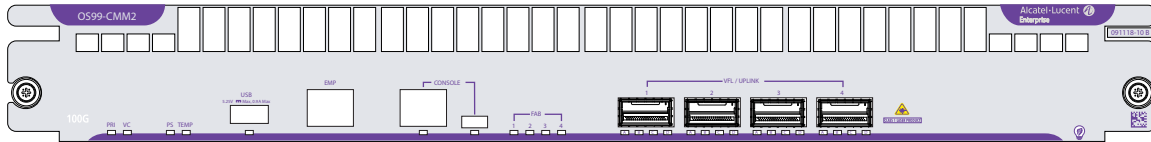

CMM Specifications

Port Types (pictured from left to right)

USB Type A: For storage devices that can download code or save configuration information, such as flash-based pen drives or external hard drives

EMP (RJ45): 10/100/1000 Base-T with auto-negotiation for out-of-band management (e.g., Telnet connection, diagnostics, downloading software, etc.)

Console (RJ45): For console or modem

Console (Micro-USB*): For console or modem

QSFP28 (Qty 4): 100G QSFP28 uplink/VFL ports

Power Consumption

74W

Number of Slots

2 (Slot positions 1 and/or 2. The slot 2 position may be used for an NI module in lieu of a secondary CMM. Note that, when an NI is installed in slot 2, CMM redundancy is not provided.)

Note: Supported on OS9912 chassis only.

***Note.** A driver is required for Micro-USB port operation. For information on downloading the driver, refer to the OmniSwitch AOS Switch Management Guide.

QSFP28 LED Display	Admin Status	Link Status	Transceiver	Traffic	VFL	Port Speed 40G (QSFP+) 4X10G (SFP+)
Off	Down	Down	N/A	N/A	N/A	N/A
Off	Up	Down	No	N/A	N/A	N/A
Green	Up	Up	Yes	blinking	No	40G (QSFP+)
Yellow	Up	Up	Yes	blinking	No	4X10G (QSFP+)
Blue	Up	Up	Yes	blinking	Yes	N/A
White	N/A	N/A	N/A	N/A	N/A	N/A

Note. Because OS99-CMMs provide splitter cable support on QSFP+ ports, port LED behavior for these switches differs from other OS9900 modules. To manually configure network LED colors, refer to the **interfaces beacon** command in the *OmniSwitch AOS Release 8 CLI Reference Guide*.

Switch Fabric

OS9907-CFM / OS9907-CFM2

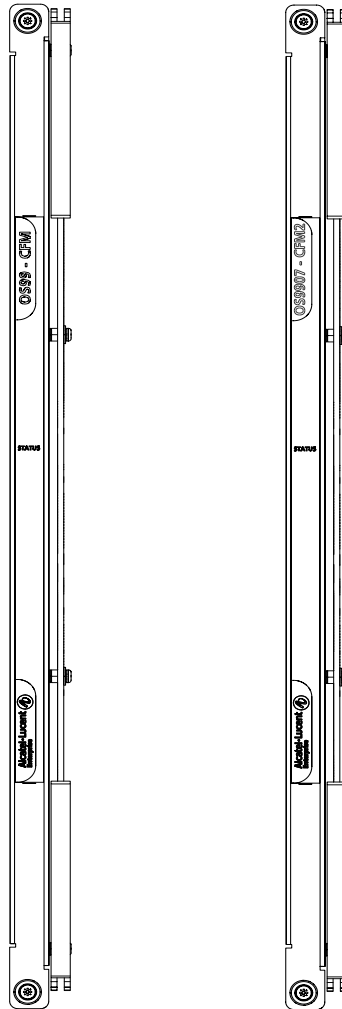

Each CFM installed provides additional fabric bandwidth to chassis management and the Network Interface (NI) modules. The chassis provides four (4) CFM slots. The modules connect to the chassis mid-plane and are located just behind the system fan trays.

CFM Specifications

Switch Fabric Bandwidth per CFM	2.56 Tbps Aggregate (OS9907-CFM) 12.8 Tbps Aggregate (OS9907-CFM2)
Number of Slots	4 (Slots CFM 3 and CFM 4 are currently inactive and are reserved for future use.)
Power Consumption	119W (OS9907-CFM and OS9907-CFM2)

Note: The OS9907-CFM2 requires a minimum AOS version of 8.9R1 and cannot be mixed with the existing OS9907-CFM in the same chassis.

OS9912-CFM

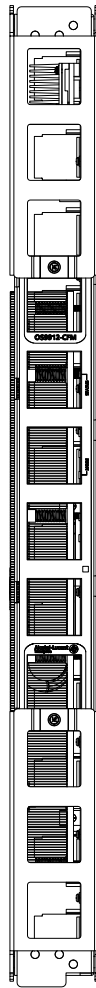

Each CFM installed provides additional fabric bandwidth to chassis management and the Network Interface (NI) modules. The chassis provides four (4) CFM slots. The modules connect to the chassis mid-plane and are located just behind the system fan trays.

CFM Specifications

Switch Fabric Bandwidth per CFM	25.6 Tbps Aggregate
Number of Slots	4
Power Consumption	222W

NI Modules

OS99-XNI-48

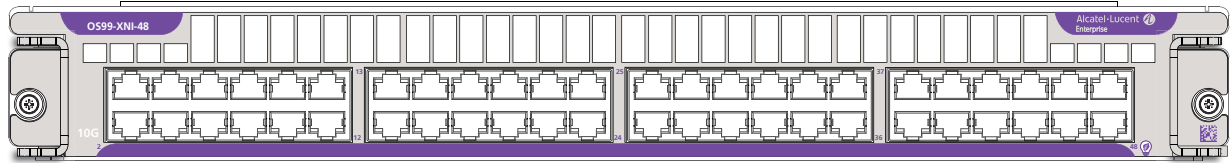

Port Type	Number of Ports	Power Consumption
1/10 GigE Base-T	48	402W

OS99-XNI-U48



Port Type	Number of Ports	Power Consumption
1/10 GigE SFP+	48	305W

OS99-GNI-48

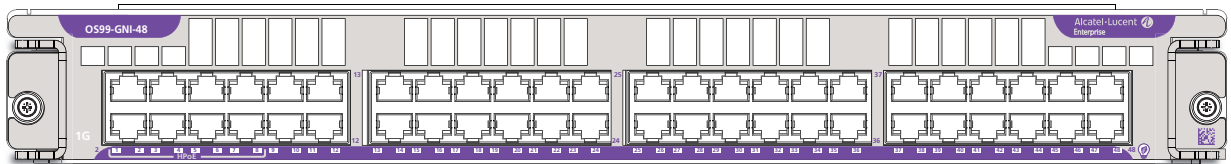

Port Type	Number of Ports	Power Consumption
10/100/1000 Base-T	48	56W

OS99-GNI-P48

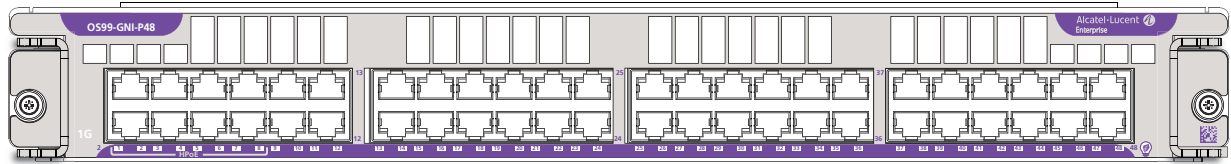

Port Type	Number of Ports	Power Consumption
10/100/1000Base-T PoE	48	54W, excluding any attached Powered Devices (PDs)
HPoE Ports	Ports 1 through 8 support HPoE (75W). These ports are labeled “HPoE” on the chassis front panel.	

OS99-GNI-U48



Port Type	Number of Ports	Power Consumption
1 GigE SFP	48	70W

OS99-XNI-P48Z16



Port Type	Number of Ports	Power Consumption
1/2.5/5/10 GigE BaseT 802.3at PoE	16	402W, excluding any attached Powered Devices (PDs)
1/10 GigE Base-T 802.3at PoE	32	
HPoE Ports	Ports 1 through 8 support HPoE (75W).	

Note: Not supported in an OS9912 chassis.

OS99-CNI-U8

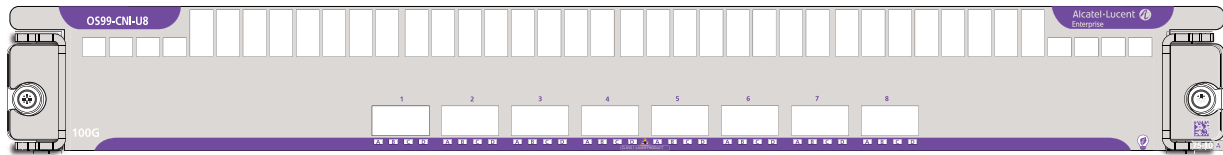

Port Type	Number of Ports	Power Consumption
10/25/40/50/100 GigE QSFP28	8	117W

OS99-XNI-U24

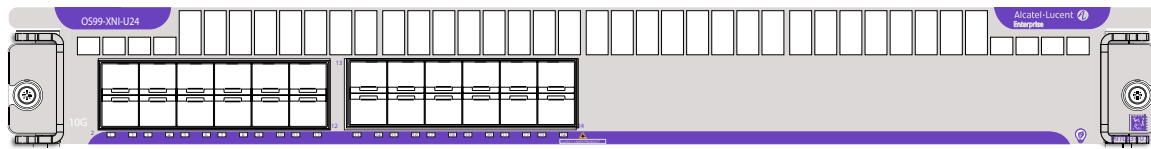

Port Type	Number of Ports	Power Consumption
1/10 GigE SFP+	24	153 W

OS99-XNI-P24Z8

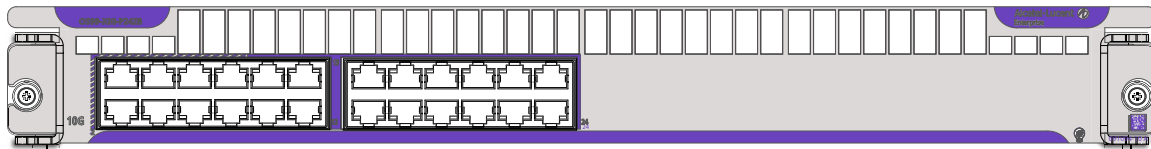

Port Type	Number of Ports	Power Consumption
1/2.5/5/10 GigE BaseT 802.3at PoE	8	187W, excluding any attached Powered Devices (PDs)
1/10 GigE Base-T 802.3at PoE	16	
HPoE Ports	Ports 1 through 8 support HPoE (75W).	

Note: Not supported in an OS9912 chassis.

OS99-XNI-UP24Q2

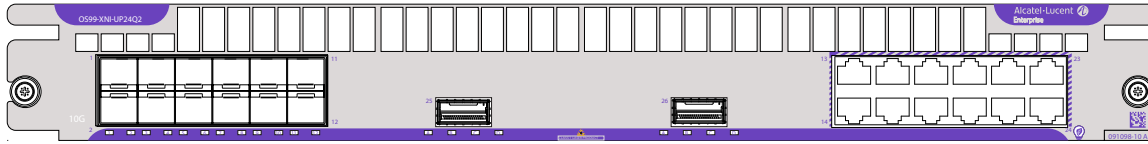

Port Type	Number of Ports	Power Consumption
10GBase SFP+	12	117W, excluding any attached Powered Devices (PDs)
1/2.5/5/10GBaseT HPoE (75W)	12	
40GBase QSFP+	2	

Note: Not supported in an OS9912 chassis.

OS99-XNI-U12Q

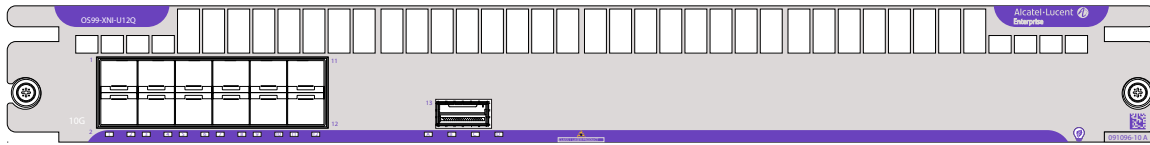

Port Type	Number of Ports	Power Consumption
10GBase SFP+	12	117W
40GBase QSFP+	1	

Note: Not supported in an OS9912 chassis.

OS99-CNI-U20

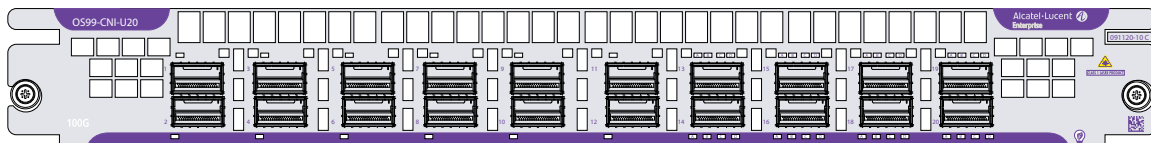

Port Type	Number of Ports	Power Consumption
100GBase QSFP28	20 (13-20 support splitter function)	314W

NI Module LEDs

NI Module LEDs	
Backlight Status LED	Located at the module product name at the upper-left corner of the front panel Solid Blue: HW OK Blinking Blue HW Bootup or HW Failure
Speed LED	Located at the left side of the front panel and indicates the maximum port speed for the module (e.g., 10G) Solid Green: HW OK Solid Red: HW Failure Blinking Green: SW OK (Heartbeat); the module is booted and operating normally Solid Yellow: SW System Failure
Power Save LED	Reserved for future use
Port Status LEDs	Solid Green: Non-PoE Port Link Blinking Green: Non-PoE Port Link and Activity Solid Yellow: PoE Port Link (PoE modules only) Blinking Yellow: PoE Port Link and Activity (PoE modules only)

OS99-CNI-U8 LED Display	Admin Status	Link Status	Transceiver	Traffic	VFL	Port Speed
Off	Down	Down	N/A	N/A	N/A	N/A
Off	Up	Down	No	N/A	N/A	N/A
Green (A)	Up	Up	Yes	blinking	No	40G/100G
Green (A/B/C/D)	Up	Up	Yes	blinking	No	4X25G 4X10G
Blue	Up	Up	Yes	blinking	Yes	N/A

Fan Trays

The chassis provides three (3) fan tray slots for chassis air and temperature control.

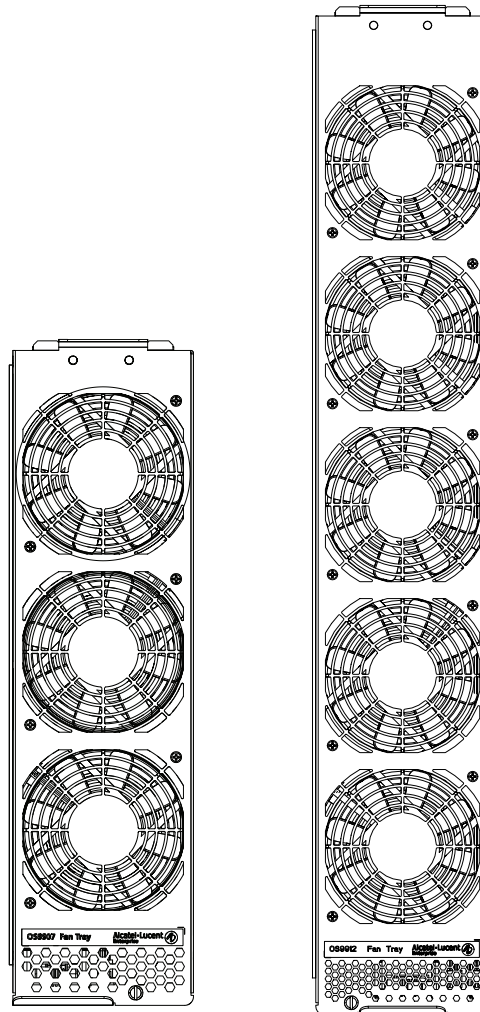

Fan Tray Specifications

Number of Fan Tray Slots	OS9907 - 3 (with three fans per tray for N+1 fan redundancy) OS9912 - 3 (with five fans per tray for N+1 fan redundancy)
Airflow Direction	Front-to-back only
Hot Swapping	Supported (Three fan trays are required at all times; removal of a fan tray is allowed for fan tray or CFM field replacement only.)
Power Consumption	OS9907 - 112W OS9912 - 200W

Power Supplies

Note: Mixing of AC and DC power supplies is not supported. Mixing of Hi (240VAC) and Low (110VAC) input is not supported.

Branch Circuit Protection: ALE recommends using circuit breakers that are rated for 30A (AC) and 110A (DC) per power supply.

OS99-PS-A (AC Power Supply)

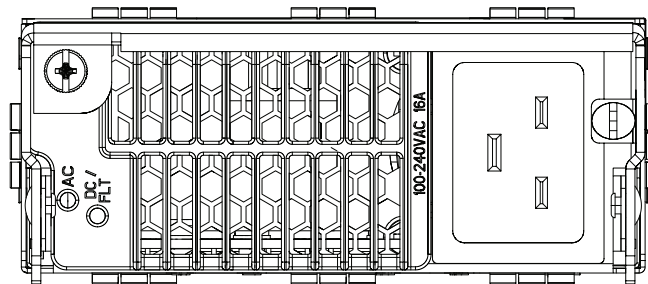

OS99-PS-A Specifications

Input Voltage/Current	100 VAC (13.8A) to 240V AC (16.5 A)
Max Output Power/Current	1200 W/21.4 A 3000 W/53.5 A
Dimensions	1.63 in x 4 in x 17.2 in
Weight	4.8 lb (2.18 kg)
Hot Swapping	Supported
Provides Power for	System and PoE

OS99-PS-D (DC Power Supply)

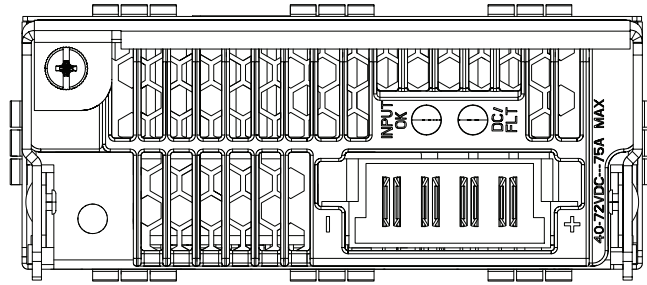

OS99-PS-D Specifications

Input Voltage/Current	-40 VDC to -72 VDC / 75 ADC (At input voltages > 40 VDC)
Max Output Power	2500 W (44 - 58 VDC)
Max Output Current	44.6 A @ 56 VDC
Dimensions	1.63 in x 4 in x 17.2 in
Weight	4.6 lb (2.1 kg)
Hot Swapping	Supported
Provides Power for	System and PoE

DC Power Supply Connection

Connecting a DC Cable Harness to the Chassis Power Supply

When plugging in the cable, insert the connector end of the cable harness into the power supply connector until it clicks firmly into place. This is an indication that the connector is secure and properly seated.

Connecting a DC Cable Harness to the DC Power Source

The other end of the cable harness is bare. Users must assemble and connect this end to the DC power source or to a cable coming from the power source. In addition to following the important guidelines listed below, be sure to consult manufacturer specifications for the DC power source before starting.

- Connect the power supply to a reliably grounded 48V or 60V SELV source.
- The branch circuit overcurrent protection must be rated 75A.
- Use two 10 AWG copper conductors.
- A readily accessible disconnect device that is suitably approved and rated shall be incorporated in the field wiring.
- The above product(s) shall be installed in a restricted access location.

- The power supply shall used with an 4P PWRBLADE CONNECTOR, FCI model 10080598-2ED0006LF.

CAUTION: Installation of a DC cable that is more than 3 meters in length is subject to LOCAL CODES and AUTHORITIES. Please contact your electrician and the Local AHJ (Authority Having Jurisdiction) to follow the Electrical Codes before use of proper installation methods.

2 Getting Started and Installation

Getting Started

Preparing for the Installation

- Alcatel-Lucent Enterprise products must be installed by a professional installer. It is the responsibility of the installer to comply with product specifications and all applicable local and national codes.
- When preparing for installation, unpack the product as close as possible to the location where it will be installed.
- Do not attempt to move or install a fully loaded chassis. To avoid injury and/or damage to the product, two or more people are required when lifting.

Elevated Operating Ambient Temperature

If installed in a closed or multi-rack assembly, the operating ambient temperature of the rack environment may be greater than the room's ambient temperature. Therefore, consideration should be given to the maximum rated ambient temperature (T_{mra}).

Reduced Air Flow

Installation of the equipment should be such that the amount of air flow required for safe operation of the equipment is not compromised. Refer to [“Airflow Considerations” on page 2-29](#) for more information.

Mechanical Loading

Mounting of the equipment in the rack should be such that a hazardous condition is not achieved due to uneven loading.

Circuit Overloading

Consideration should be given to the connection of the equipment to the supply circuit and the effect that overloading of circuits could have on overcurrent protection and supply wiring. Appropriate consideration of equipment nameplate ratings should be used when addressing this concern.

Reliable Earthing

Reliable earthing of rack-mounted equipment should be maintained. Particular attention should be given to supply connections other than direct connections to the branch (e.g., use of power strips).

OmniSwitch 9900 Series switches have the following general electrical requirements:

- Each switch requires one grounded electrical outlet *for each power supply installed in the chassis*.
- OmniSwitch 9900 Series switches offer both AC and DC power supply support.
- For switches using AC power connections, each supplied AC power cord is 2 meters (approx. 6.5 feet). Do not use extension cords.
- ALE provided power cords are UL recognized to IEC 62368-1 exceeding the maximum amperage requirement for the power source. If using a non-ALE provided power cord the installer shall confirm it meets the minimum electrical requirements of the power source.

Redundant AC Power. It is recommended that each AC outlet resides on a separate circuit. With redundant AC power, if a single circuit fails, the switch's remaining power supplies (on separate circuits) can remain operational.

For switches using DC power, refer to [“DC Power Supply Connection” on page 1-25](#) for more information.

Electrical Surge Warning

In order to help protect equipment against electrical surges please take note of the following recommendations and guidelines:

1. Earth grounding of all devices is fundamental to ensure long term reliability.
 - All electrical equipment must be installed by a qualified, licensed electrician.
 - Every power supply that is connected to building power should be earth grounded.
 - Earth grounding for the power cable, should be verified to be 0.01 ohm or less.
 - Each switch should be grounded to same earth ground as the power supply.
 - Each powered device, such as an AP or camera, should be connected to earth ground.
 - Each surge suppression device should be connected to earth ground.
2. Shielded cables (STP) offer some minimal level of additional protection over unshielded Ethernet cables (UTP) but the use of a surge protector is still recommended.
 - It is suggested to use STP Cat5e or better for 1Gbps Ethernet switches for any outdoor application or applications where Ethernet cables come in close proximity to alternating current conductors.
 - Always install cables according to manufacturer requirements.
3. For any connections where integrity of the cabling within a building ground is questionable (i.e outdoor connections), copper Ethernet ports must be connected with an appropriate surge protection device, inline, between the PSE and PD per the manufacturer's recommendations for connection and grounding.
4. Caution should be taken for any cable connected to any outdoor device, not only on the device grounding, but to ensure that any outdoor device cables that could carry surge currents, do not pass those surge currents to upstream Ethernet switches.

Caution - Category 5e, Category 6, and Category 6a cables can store large amounts of static electricity due

to the dielectric properties of their construction materials in addition, this build up of electricity could lead to a Cable Discharge Event (CDE). A CDE can occur due to the differential in charges on the cable and the equipment it's being connected to. It is recommended that installers momentarily ground all copper Ethernet cables (especially in new cable runs) to a suitable and safe earth ground before connecting them to the port.

Items Included

Depending on your order the following items may be included:

- OmniSwitch Chassis with power supplies and modules
- Country specific power cord(s)
- Cover Panels
- Rack Mount Brackets
- Product Documentation and Training Cards
- DB9-RJ45 Connector
- Grounding Wrist Strap

Airflow Considerations

To ensure proper airflow, be sure that the switch is placed in a clean, well-ventilated area free of dust and debris and provide minimum recommended clearance at the front, back and sides of the switch.

Never obstruct chassis or component air vents. Restricted airflow can cause the switch to overheat, which can lead to system failure and damage to the product.

Note. Clearance is not required at the top and bottom of the chassis.

Blank Cover Panels

Blank cover panels are used to cover empty module slots and power supply bays. Because they regulate airflow and help protect internal chassis components, blank cover panels should be installed over empty module slots and power supply bays at all times.

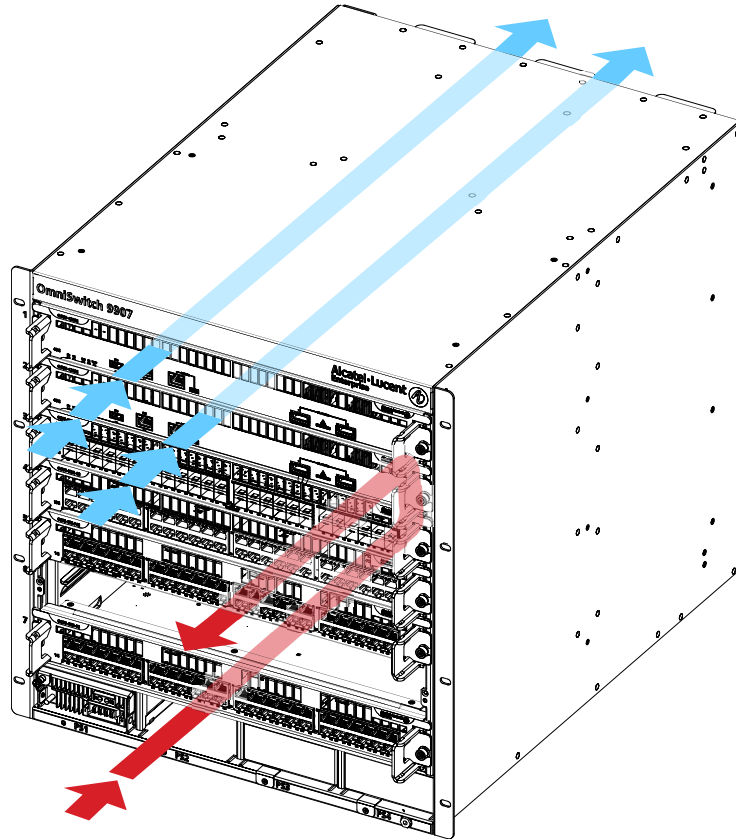

Missing Blank Cover Panels Adversely Affect Chassis Airflow

Mounting the Chassis

Note. Due to weight and airflow requirements, OS9900 switches cannot be wall mounted.

Standalone (Non-Rack Mounted) Installation

The chassis can be placed unmounted on a stable, flat surface as a standalone unit. Be sure that the surface can accommodate the full, populated weight of all switches being installed. Approximate chassis weights are provided in [“OmniSwitch 9907 Series” on page 1-2](#) and [“OmniSwitch 9912 Series” on page 1-8](#).

For a standalone unit, use two or more people to move and position the unpopulated chassis upright on the surface where it is to be installed. Be sure that adequate clearance has been provided for chassis airflow and that you have placed the chassis within reach of all required AC outlets. For recommended airflow allowances, refer to [“Airflow Considerations” on page 2-29](#).

Note. The chassis must be placed “right side up.” Never attempt to operate a switch while it is lying on its side or back.

Rack Mounting

General Rack Mounting Recommendations

- Install the switch in the rack using the rack manufacturer’s recommended attachment screws (not provided). Always follow rack manufacturer’s specifications when installing.
- The OmniSwitch 9907 is an 11 RU high unit and the OmniSwitch 9912 is 17 RU high.
- Pre-marking the holes on the rack where the switch is to be installed can be helpful when installing multiple switches in a rack.
- Use two additional people to help lift and position the chassis in the rack during installation.
- To keep the rack from becoming top heavy, install switches toward the bottom of the rack first.

Non-Standard Rack-Mounting Hardware

All OmniSwitch switches are shipped with integral front rack mount flanges. These flanges support standard 19” rack mount installations. For non-standard rack mount requirements, contact Alcatel-Lucent Enterprise for information on optional hardware availability.

Installing Chassis Components

Installing Fabric Modules

To access CFM slots, be sure the fan trays covering the slots have been removed. (For information on removing fan trays, refer to [“Removing Fan Trays” on page 4-53](#).)

1. To install a CFM, orient the module so the top (component side) of the circuit board faces left.

Insert the edges of the circuit board into the card guides at top and bottom (see inset) and partially slide the module back toward the chassis mid-plane.

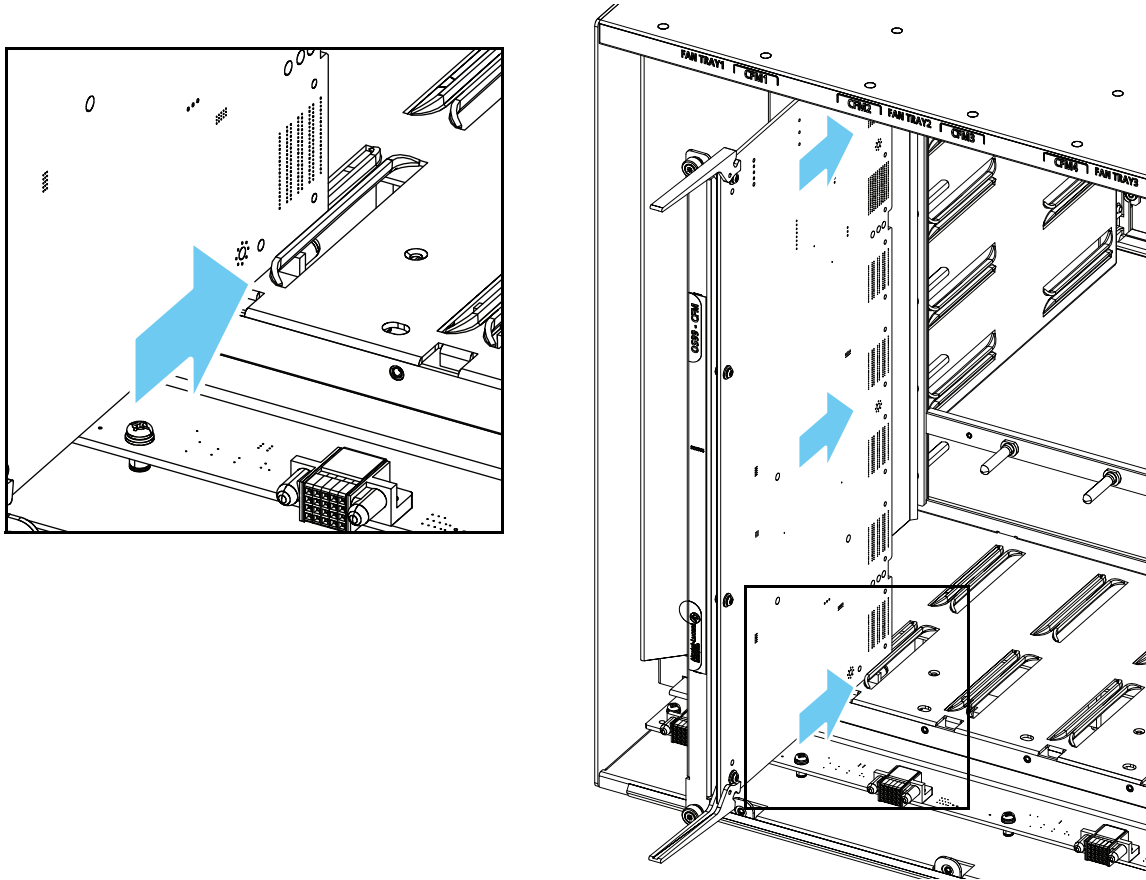

2. When the module reaches the mid-plane connectors, hold the top and bottom lock levers in the open position and slide the module back until it stops.

3. Simultaneously press the top and bottom lock levers until the levers are in the vertical (locked) position and the module is firmly seated in the chassis mid-plane.

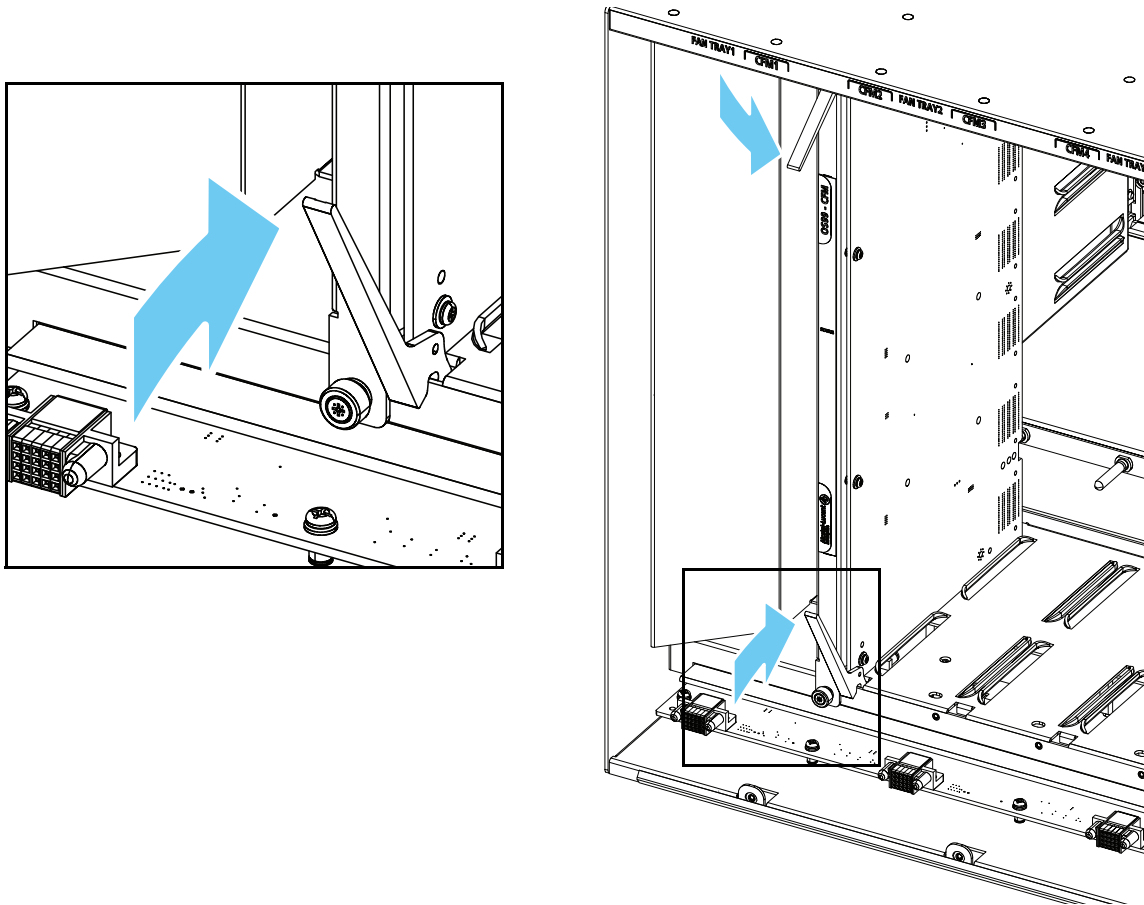

4. Hand-tighten the captive screws at the top and bottom of the module.
5. Repeat these steps for additional CFMs (if applicable).
6. Install fan trays as needed. (For information on installing fan trays, refer to [“Installing Fan Trays”](#) on [page 2-34](#).)

Installing Fan Trays

1. Fan trays are secured by two tabs at the top of the unit and a captive thumb screw at the bottom of the unit. Hold the fan tray by the top and bottom handles. Angle the tray away from the chassis at the bottom, as shown, and insert the tabs at the top of the fan tray slot.

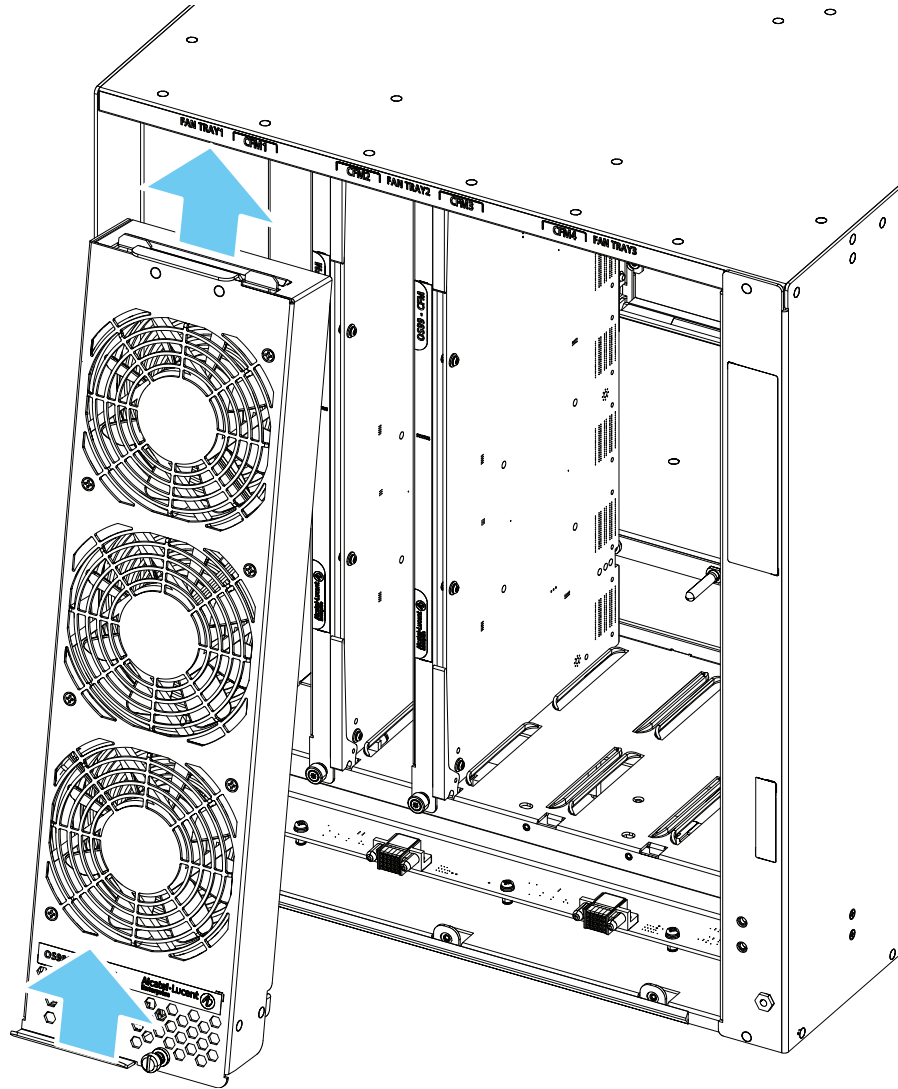

2. With the top tabs inserted, push the bottom of the tray into the slot until it is firmly seated.

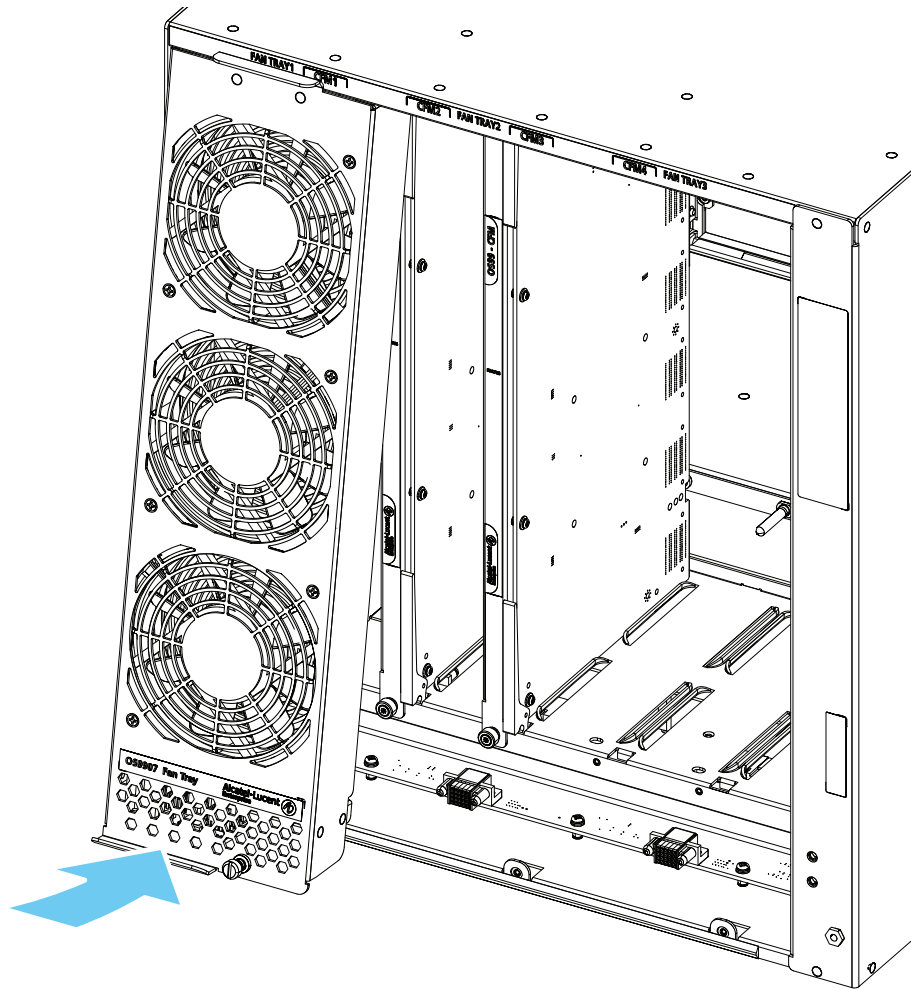

3. Hand-tighten the thumb screw.

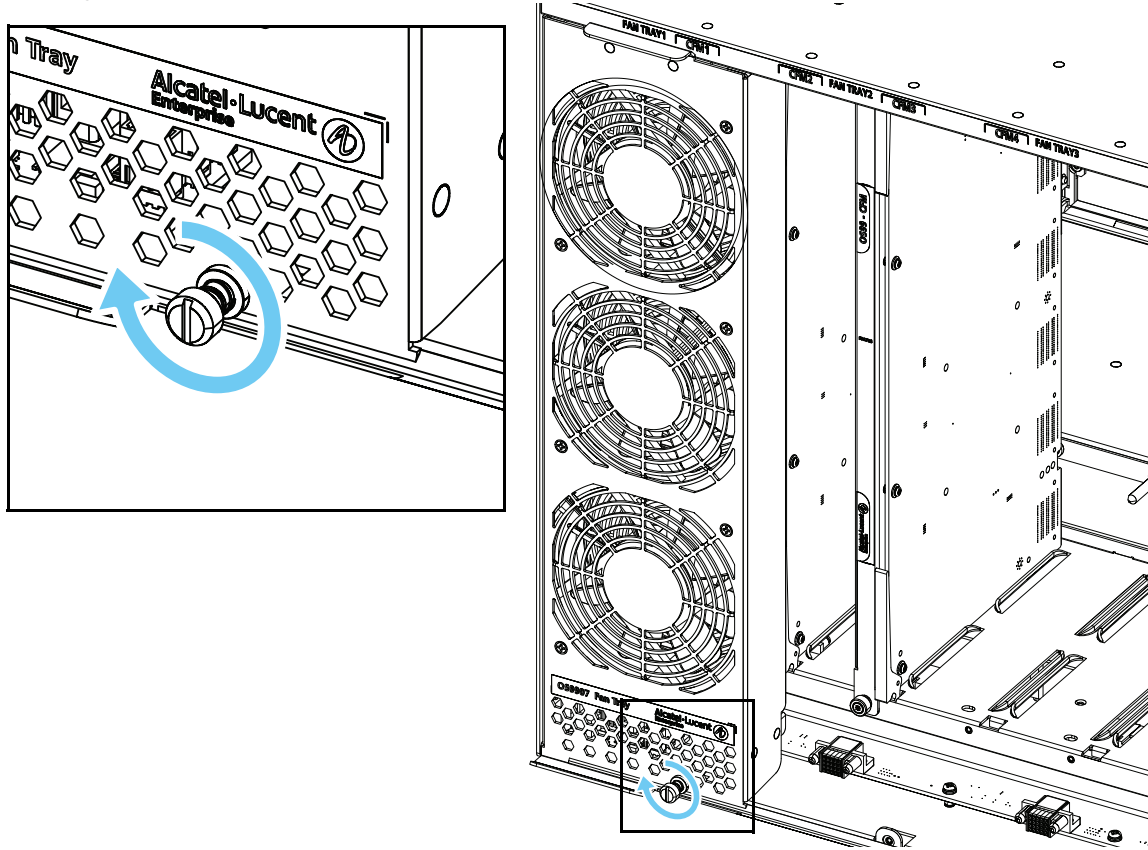

Installing Modules

1. To install a module, insert the edges of the circuit board into the grooves at the left and right sides of the chassis.

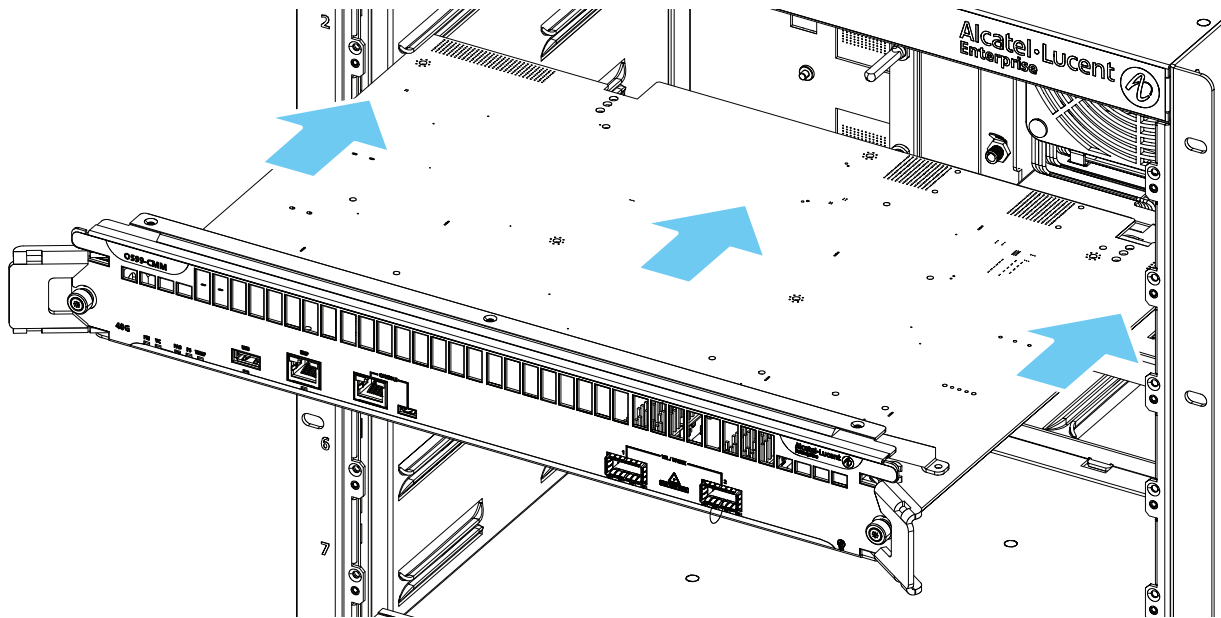

2. Be sure the lock levers are in the open position and slide the module back until it meets the backplane connectors.
3. Tighten the lock levers by pulling them inward (toward the center of the module's front panel). When the modules are fully closed (at a 90 degree angle with the front panel), the module will be firmly seated.

When the module is fully seated, hand-tighten the thumb screws at the left and right sides of the module.

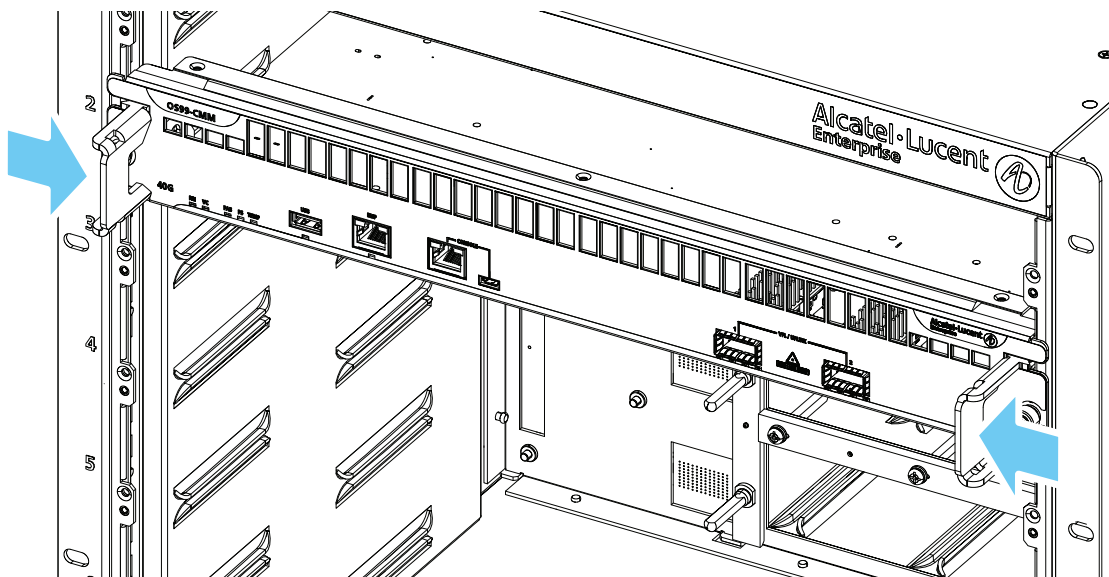

Installing a Power Supply

Once the chassis components have been installed, install the power supplies.

Note. When connecting or disconnecting a power supply to/from a chassis, the power supply must first be disconnected from the power source.

1. Remove blank cover panel from the power supply slot (if applicable) and store the cover panel for future use.
2. With one hand, hold the front of the power supply. Place your other hand under the power supply to support its weight. Insert the rear of the power supply into the slot. Be sure the handle is in the down (open) position and slide the unit back until it meets the chassis backplane.

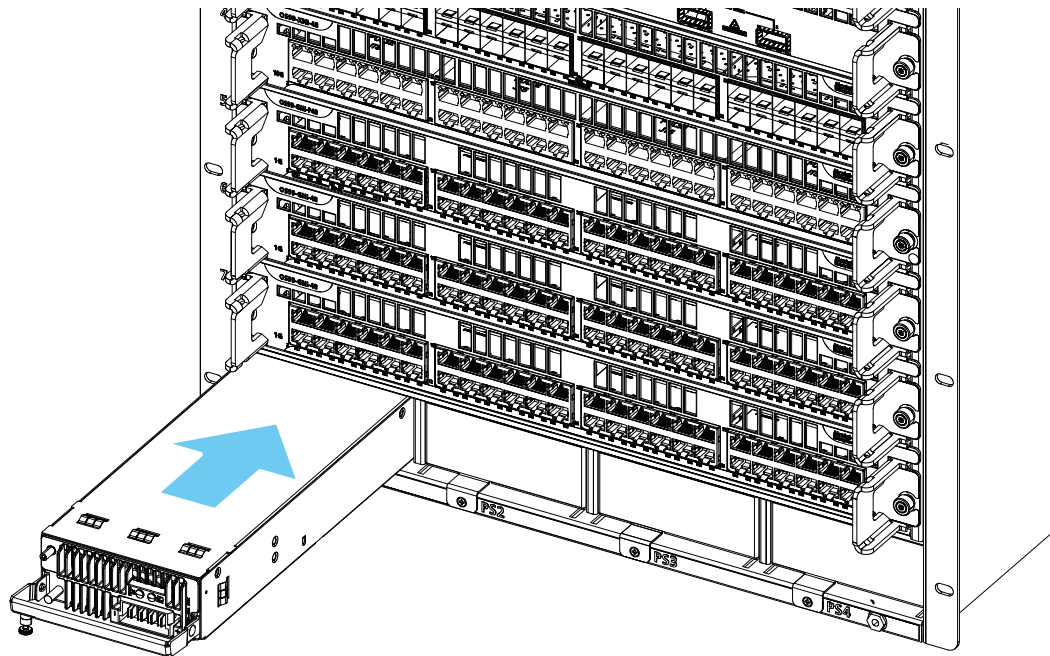

3. Press the handle up into the vertical (locked) position. The power supply should be fully seated in the chassis backplane. Tighten the thumb screw to secure the power supply.

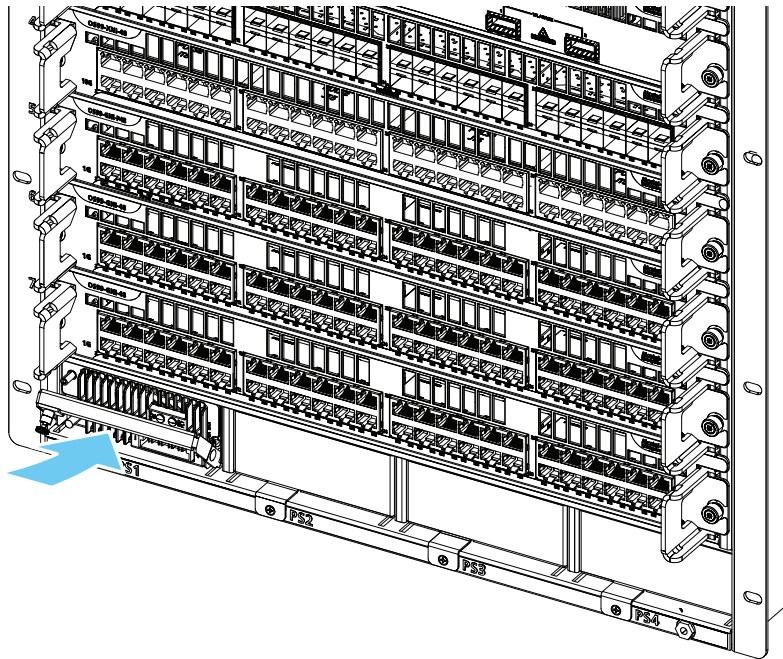

4. Plug in the power cord and then plug the power cord into an easily-accessible, properly grounded outlet. (Do not use an extension cord.)

Connections and Cabling

Once the switch is properly installed, connect all network and management cables required network applications.

Network Cable Installation Warning

Never install exposed network cables outdoors. Install network cables per manufacturer requirements.

For additional information on cabling for console, EMP, USB, Bluetooth and other connections, refer to the *OmniSwitch AOS Switch Management Guide*.

Serial Connection to the Console Port

The console port provides a serial connection to the switch using either a Micro-USB or RJ45 connector and is required when logging into the switch for the first time.

Serial Connection Default Settings

baud rate	9600
parity none	none
data bits (word size)	8
stop bits	1

For information on modifying these settings, refer to the *OmniSwitch AOS Switch Management Guide*.

Ethernet Management Port (EMP) Cable Requirements

There are specific cable type requirements (i.e., straight-through or crossover) based on the device to which the EMP is connecting. Refer to the information below:

Serial Connection Default Settings	
EMP to a Switch	Straight-through
EMP to a Computer or Workstation	Crossover

For information on manually configuring Ethernet ports, refer to the *OmniSwitch AOS Switch Management Guide*.

Booting the Switch

To boot the switch, plug all power supply cords into easily-accessible, properly grounded power outlets. (Do not use extension cords). The switch will power on and boot automatically.

Note. If more than one power supply is installed, be sure to plug in each power supply in rapid succession, (i.e., within a few seconds of each other). This ensures that there will be adequate power for all components throughout the boot process.

Component LEDs

During the boot process, component LEDs will flash and change color, indicating different stages of the boot. Following a successful boot, LEDs on the primary CMM should display as follows:

PRI	Solid Green
PS	Solid Green
FAB	Solid Green
TEMP	Solid Green

Note. Be sure the boot process is complete before checking LED status. If LEDs indicate persist errors, contact Alcatel-Lucent Customer Support.

Once the switch has completely booted, connect to the console port and log in to the switch's Command Line Interface (CLI) and configure basic information. Continue to [“The First Login Session” on page 2-40](#).

The First Login Session

To complete the setup process, follow these steps during the first login session:

- Log in to the switch
- Set IP address information for the Ethernet Management Port (EMP)
- Unlock session types
- Change the login password
- Set the date and time
- Set optional system information
- Save changes

Important. Connect to the switch via the console port before initiating the first login session.

Logging In to the Switch

At the login and password prompts, use the switch's default settings:

Login	admin
Password	switch

The default welcome banner, which includes information such as the current software version and system date, is displayed followed by the CLI command prompt:

```
Welcome to the Alcatel-Lucent Enterprise OS9900 8.3.1, June 03, 2016.
Copyright (c) 1994-2014 Alcatel-Lucent. All Rights Reserved.
Copyright (c) 2014-2016 Alcatel-Lucent Enterprise. All Rights Reserved.
OmniSwitch(tm) is a trademark of Alcatel-Lucent,
registered in the United States Patent and Trademark Office.
```

Note. A user account includes a login name, password, and user privileges. Privileges determine whether the user has read or write access to the switch and which commands the user is authorized to execute. For detailed information on setting up and modifying user accounts, refer to the *OmniSwitch Switch Management Guide*.

Setting IP Address Information for the EMP

The IP address may be set via the Ethernet Management Port (EMP). To connect to the switch through the EMP Ethernet connection, use the default address below or change the port's IP address.

Default EMP IP Address	192.168.1.1
Default EMP Mask	255.255.255.0

Note. Connect to the switch via the console port before attempting to change IP address information.

To change the default IP and mask, use the **ip interface** command. For example:

```
-> ip interface emp address 168.22.2.120 mask 255.255.255.0
```

Verify the settings using the **show ip interface** command. See the *OmniSwitch AOS Switch Management Guide* for additional information regarding EMP port addressing.

Note. The switch cannot be accessed through this port (i.e. TELNET, FTP, HTTP, SSH or SNMP) until these remote session types have been unlocked. See “Unlocking Session Types,” below, for more information.

Unlocking Session Types

When accessing the switch for the first time, users must use a direct console port connection. All other session types (Telnet, FTP, WebView, and SNMP) are locked out until they are manually unlocked by the user.

The CLI command used to unlock session types is **aaa authentication**.

Note. Unlocking session types grants access to non-local sessions (e.g., Telnet). As a result, anyone with the correct user login and password will have remote access to the switch.

For more information on switch security, refer to the *OmniSwitch AOS Switch Management Guide*.

Unlocking All Session Types

To unlock all session types, enter the following command syntax at the CLI prompt:

```
-> aaa authentication default local
```

Unlocking Specific Session Types

You can also unlock specific session types (console, telnet, ftp, http, snmp, ssh). For example, to unlock Telnet sessions, enter the following command:

```
-> aaa authentication telnet local
```

Refer to the *OmniSwitch CLI Reference Guide* for complete **aaa authentication** command syntax options.

Changing the Login Password

Change the login password for admin user sessions by following the steps below:

1. Be sure that you have logged into the switch as user type *admin* (see [“Logging In to the Switch” on page 2-41](#)).
2. Type **password** at the prompt and press Enter.
3. Enter the new password at the prompt.

Note. Be sure to remember or securely record all new passwords; overriding configured passwords on an OmniSwitch is restricted.

4. You will be prompted to re-enter the password. Enter the password a second time.

New password settings are automatically saved in real time to the local user database; the user is not required to enter an additional command in order to save the password information. Also note that new password information is retained following a reboot. All subsequent login sessions, including those through the console port, will require the new password to access the switch.

For detailed information on managing login information, including user names and passwords, refer to the *OmniSwitch Switch Management Guide*.

Setting the System Time Zone

The switch's default time zone is UTC. If you require a time zone that is specific to your region, or if you need to enable Daylight Savings Time (DST) on the switch, you can configure these settings via the **system timezone** and **system daylight-savings-time** commands.

For detailed information on configuring a time zone for the switch, refer to the *OmniSwitch AOS Switch Management Guide*.

Setting the Date and Time

Set the current time for the switch by entering system time, followed by the current time in *hh:mm:ss*. To set the current date for the switch, enter system date, followed by the current date in *mm/dd/yyyy*.

Setting Optional Parameters

Specifying an Administrative Contact

An administrative contact is the person or department in charge of the switch. If a contact is specified, users can easily find the appropriate network administrator if they have questions or comments about the switch.

To specify an administrative contact, use the **system contact** command.

Specifying a System Name

The system name is a simple, user-defined text description for the switch.

To specify a system name, use the **system name** command.

Specifying the Switch's Location

It is recommended that you use a physical labeling system for locating and identifying your switch(es). Examples include placing a sticker or placard with a unique identifier (e.g., the switch's default IP address) on each chassis.

However, if no labeling system has been implemented or if you need to determine a switch's location from a remote site, entering a system location can be very useful.

To specify a system location, use the **system location** command.

Viewing Your Changes

To view your current changes, enter **show system** at the CLI prompt.

Saving Your Changes

Once you have configured this basic switch information, save your changes by entering **write memory** at the CLI command prompt.

Working with Chassis Power Budget

The power available to the chassis modules (CMM, CFM, and NI) is based on the user configuration and system environment.

Adding additional components (e.g., NI modules, a redundant CMM, or powered POE devices)—as well as removing power supplies—affects the overall power budget for the switch.

As soon as a component is inserted and its connectors make contact with the chassis mid-plane, additional power requirements take effect. If there is not adequate power, the incoming component may not power on. Additional power errors may also occur, which can interrupt data flow on the switch. So it is important to check the current chassis power before adding a module or removing a power supply to verify that the current chassis power supports the change.

Use the **show chassis** command to determine available power budget (see Power Left number).

```
-> show chassis
Local Chassis ID 1 (Master)
  Model Name:          OS9900,
  Description:        Chassis,
  Part Number:        903722-90,
  Hardware Revision:  B,
  Serial Number:      T4720029,
  Manufacture Date:   Feb  1 2016,
  Admin Status:       POWER ON,
  Operational Status: UP,
  Free Slots:         4,
  Power Left:         2041,
  Number Of Resets:   20,
  MAC Address:        2c:fa:a2:13:e4:02
```

In this example, 2041 watts are available for incoming components and/or powered devices.

3 Power Over Ethernet (PoE)

Managing Power over Ethernet (PoE)

Important: Alcatel-Lucent Enterprise recommends that PoE-enabled switches with attached IP telephones have operational power supply redundancy at all times for 911 emergency requirements. In addition, both the switch and the power supply should be plugged into an Uninterruptible Power Source (UPS).

Power over Ethernet Specifications		
Module(s) supporting PoE	OS99-GNI-P48, OS99-XNI-P48Z16, OS99-XNI-P24Z8, OS99-XNI-UP24Q2	
IEEE Standards supported	IEEE 802.3; 802.af; 802.3at	
PoE Power Supported	HPoE (75 W) 802.3at (30 W) All PoE-enabled ports are IEEE 802.3af/at compliant.	
Default PoE administrative status	Enabled	
Default PoE operational status	Disabled (PoE must be activated via the lanpower start command.)	
Power over Ethernet Settings	Default	Related Command
PoE operational status	Disabled	lanpower slot service
Maximum power available to a port	75000 milliwatts (HPoE ports) 30000 milliwatts (802.3at ports)	lanpower power
Total power available to an entire slot	1800W	lanpower slot maxpower
Power priority level for a port	low	lanpower priority
Capacitor detection method	Disabled	lanpower capacitor-detection
Priority disconnect status	Enabled	lanpower slot priority-disconnect

Viewing Power Supply Status

To view the type and status for installed power supplies, use the **show powersupply** command:

```
-> show powersupply
      Total      Power      Input      PS
```

Slot	PS	Power	Used	Voltage	Type	Status	Location
	1	1200	487	122	AC	UP	Internal
	2	0	0	0	AC	UNPLUG	Internal
	3	0	0	0	AC	UNPLUG	Internal
	Total	1200	487				

Viewing PoE Status

To view current PoE status and settings, including the amount of PoE power available for incoming powered devices, use the **show lanpower slot** command for the corresponding PoE module(s):

```
-> show lanpower slot 1/4
```

Port	Maximum(mW)	Actual Used(mW)	Status	Priority	On/Off	Class	Type
1	75000	0	Powered Off	Low	OFF	.	
2	75000	0	Powered Off	Low	OFF	.	
3	75000	0	Powered Off	Low	OFF	.	
4	75000	0	Powered Off	Low	OFF	.	
5	75000	0	Powered Off	Low	OFF	.	
6	75000	0	Powered Off	Low	OFF	.	
7	75000	0	Powered Off	Low	OFF	.	
8	75000	0	Powered Off	Low	OFF	.	
9	30000	0	Powered Off	Low	OFF	.	
10	30000	0	Powered Off	Low	OFF	.	
...							
46	30000	0	Powered Off	Low	OFF	.	
47	30000	0	Powered Off	Low	OFF	.	
48	30000	0	Powered Off	Low	OFF	.	

```
ChassisId 1 Slot 4 Max Watts 0
0 Watts Actual Power Consumed
ChassisId 1 Slot 4 Max Watts Running 0
0 Watts Total Power Budget Used
2041 Watts Total Allocated PoE Power
2041 Watts Total Power Budget Available
2 Power Supplies Available
```

PoE Class Detection

Powered devices can be classified into different classes as shown in the table below. Class detection allows for automatic maximum power adjustment based on the power class detected. This will prevent the switch from delivering more than the maximum power allowed based on a device's class.

During class detection, the switch will allocate the maximum amount of power allowed based on the class detected. Once powered, if the device uses less than the maximum, the remaining power will be made available for other devices.

Class	Usage Classification	Current (mA)	Power Range (Watts)	Class Description
0	Default	0-4	0.44-30.00	Unimplemented
1	Optional	9-12	0.44-3.84	Very Low Power
2	Optional	17-20	3.84-6.49	Low Power
3	Optional	26-30	6.49-12.95	Mid Power
4	Optional	36-44	12.95-30.00	High Power

Although class-detection is disabled by default, the PoE module still provides power to incoming PDs (if available in the power budget). However, to strictly enforce class detection as specified in the 802.3at standard, class detection must be enabled using the **lanpower slot class-detection** command. Enabling class detection will reset all PoE ports.

PoE Operational Status

Enabling PoE

By default, PoE is administratively enabled in the switch's system software. However, in order to physically activate PoE, you must issue the **lanpower slot service** command on a slot-by-slot basis before any connected devices will receive inline power.

To activate power to PoE-capable in a switch, enter the corresponding slot number only. For example:

```
-> lanpower slot 2/1 service start
```

If power to a particular port has been administratively disconnected, you can reactivate power to the port using the **lanpower port admin-state** command. For example:

```
-> lanpower port 2/1/1-24 admin-state enable
```

Note. You cannot use the **lanpower port admin-state** command to initially activate PoE on a port. This syntax is intended only to reactivate power to those that have been disconnected via the **lanpower slot service** command. To initially activate PoE, you must use the **lanpower slot service** command as described above.

Disabling PoE

To disable PoE on a particular port, use the **lanpower port admin-state** command. For example:

```
-> lanpower port 1/1/12 admin-state disable
```

To disable PoE for all PoE-capable ports in a slot, use the **lanpower slot service** command. For example:

```
-> lanpower slot 1/1 service stop
```

Configuring the Total Power Available to a Port

By default, each port is authorized by the system software to use up to a maximum amount of milliwatts to power any attached device. This value can be increased or decreased based on the allowed ranges.

Increasing the total power available to an individual port may provide a more demanding powered device with additional power required for operation. Decreasing the total power available to a port helps to preserve inline power and assists in the overall management of the switch's power budget.

To increase or decrease the total power available to an individual port, use the **lanpower power** command.

Note. Since the power allowance is being set for an individual port, chassis/slot/port values must be specified.

Configuring the Total Power Available to a Slot

Like the maximum port power allowance, the system software also provides a maximum slot-wide power allowance. By default, each slot is authorized by the system software to use a number of watts to power all devices connected to its ports depending on which power supply is used.

As with the maximum port power allowance, the user can either increase or decrease this value based on the allowed ranges.

Note. Decreasing the slot-wide power could cause lower priority ports to lose power if the new value is less than the total PoE power currently being consumed.

To increase or decrease the total power available to a slot, use the **lanpower slot maxpower** command. Since you are setting the power allowance for an individual slot, you must specify a chassis/slot value in the command line. For example, the syntax

```
-> lanpower slot 3/1 maxpower 400
```

reduces the power allowance of chassis 3, slot 1 to 400 watts. This value is now the maximum amount of power the slot can use to power all attached devices (until the value is modified by the user).

Note. Changing the maximum power available to a slot or port does not reserve or immediately allocate that power. These settings are only used for configuring a maximum amount of power that may be used, any unused power is still available and remains a part of the overall PoE budget.

Setting Timers and Other User-Defined PoE Power Rules

The **lanpower power-rule** command allows user to set additional rules for PoE power (e.g., setting PoE to turn on or off on specific dates or at specific times). Refer to the *OmniSwitch AOS CLI Command Reference Guide* for more information.

Setting Port Priority Levels

As not all Powered Devices (PDs) connected to the switch have the same priority within a network setting, the OmniSwitch allows the administrator to specify priority levels on a port-by-port basis. Priority levels include low, high, and critical.

The default priority level for a port is low.

- **Low.** This default value is used for port(s) that have low-priority devices attached. In the event of a power management issue, inline power to low-priority is interrupted first (i.e., before critical and high priority).
- **High.** This value is used for port(s) that have important, but not mission-critical, devices attached. If other ports in the chassis have been configured as critical, inline power to high-priority is given second priority.
- **Critical.** This value is used for port(s) that have mission-critical devices attached, and therefore require top (i.e., critical) priority. In the event of a power management issue, inline power to critical is maintained as long as possible.

To change the priority level for a particular port, use the `lanpower priority` command. Since the switch allows you to set priority levels on a port-by-port basis, be sure to specify chassis/slot/port information in the command line. For example, the syntax

```
-> lanpower port 1/1/6 priority critical
```

changes the priority value of port 6 to the highest priority level of critical. Now that the default value has been reconfigured, this port should be reserved for those PDs that are mission critical for network operations.

Setting the Capacitor Detection Method

By default, the capacitor detection method is disabled. To enable it, use the `lanpower capacitor-detection` command. For example:

```
-> lanpower slot 3/1 capacitor-detection enable
```

Note. The capacitive detection method should only be enabled to support legacy IP phones. This feature is not compatible with IEEE specifications. Please contact your Alcatel-Lucent sales engineer or Customer Support representative to find out which Alcatel-Lucent IP phones models need capacitive detection enabled.

Understanding Priority Disconnect

Priority disconnect is used by the system software in determining whether an incoming PD will be granted or denied power when there are too few watts remaining in the PoE power budget for an additional device. For example, if there are only 2 watts available in the current PoE power budget and a user plugs a 3.5W powered device into a PoE port, the system software must determine whether the device will be powered on.

Based on priority disconnect rules, in some cases one or more existing devices may be powered down in order to accommodate the incoming device. In other cases, the incoming device will be denied power.

Priority disconnect rules involve the port priority status of an incoming device (i.e., low, high, and critical), as well as the port's physical port number. Understanding priority disconnect rules is especially helpful in avoiding power budget deficits and the unintentional shutdown of mission-critical devices when PDs are being added in tight power budget conditions.

Reminder. Priority disconnect applies only when there is inadequate power remaining in the power budget for an incoming device.

For information on setting the priority disconnect status, refer to the section below. For information on setting the port priority status (a separate function from priority disconnect), refer to [“Setting Port Priority Levels” on page 3-49](#).

Setting Priority Disconnect Status

By default, priority disconnect is enabled in the switch's system software. For information on changing the priority disconnect status, refer to the information below.

Disabling Priority Disconnect

When priority disconnect is disabled and there is inadequate power in the budget for an additional device, power will be denied to any incoming PD, regardless of its port priority status (i.e., low, high, and critical) or physical port number.

To disable priority disconnect, use the `lanpower slot priority-disconnect` command. For example:

```
-> lanpower slot 2/1 priority-disconnect disable
```

Enabling Priority Disconnect

To enable priority disconnect, use the `lanpower slot priority-disconnect` command. For example:

```
-> lanpower slot 2/1 priority-disconnect enable
```

Priority Disconnect is Enabled; Same Priority Level on All Devices

Reminder. Priority disconnect examples are applicable only when there is inadequate power remaining to power an incoming device.

When a PD is being connected to a port with the same priority level as all other in the slot, the physical port number is used to determine whether the incoming PD will be granted or denied power. Due to the support of different PoE standards and PoE hardware on each platform the internal port priority is different for each platform. The following tables should be used to determine PoE priority:

PoE Physical Port Priority

48 (Highest) -> 1 (Lowest)

Priority Disconnect is Enabled; Incoming PD Port has Highest Priority Level

Reminder. Priority disconnect examples are applicable only when there is inadequate power remaining to power an incoming device.

When a PD is being connected to a port with a higher priority level than all other in the slot, the incoming PD will automatically be granted power over the other devices, regardless of its physical port number.

In order to avoid a power budget deficit, another port in the slot is disconnected. In determining which port to power off, the system software first selects the port with the lowest configured priority level. For example, if a critical priority device is being added to a slot in which five existing devices are attached to high priority and one device is attached to a low priority port, the low priority port is automatically disconnected, regardless of its physical port number.

If all existing devices are attached to with the same lower priority level, the system software disconnects the port with both the lowest priority level and the highest priority physical port number. For example, if a critical priority device is being added to a slot in which six existing devices are attached to high priority, the high priority port with the lowest physical port priority number is automatically disconnected.

Priority Disconnect is Enabled; Incoming PD Port has Lowest Priority Level

Reminder. Priority disconnect examples are applicable only when there is inadequate power remaining to power an incoming device.

When a PD is being connected to a port with a lower priority level than all other in the slot, the incoming PD will be denied power, regardless of its physical port number. Devices connected to other higher-priority will continue operating without interruption.

Priority Disconnect is Disabled

Reminder. Priority disconnect examples are applicable only when there is inadequate power remaining to power an incoming device.

When priority disconnect is disabled, power will be denied to any incoming PD, regardless of its port priority status (i.e., low, high, and critical) or physical port number.

4 Removing Chassis Components

Removing Chassis Components

Removing a Power Supply

1. Unplug the power cord from the power source, as well as from the socket on the power supply's front panel, then loosen the thumb screw at the front of the power supply.

Note. Whenever disconnecting a power supply from a chassis, the power supply must first be disconnected from the power source.

2. Pull the power supply's handle down into the horizontal (open) position.

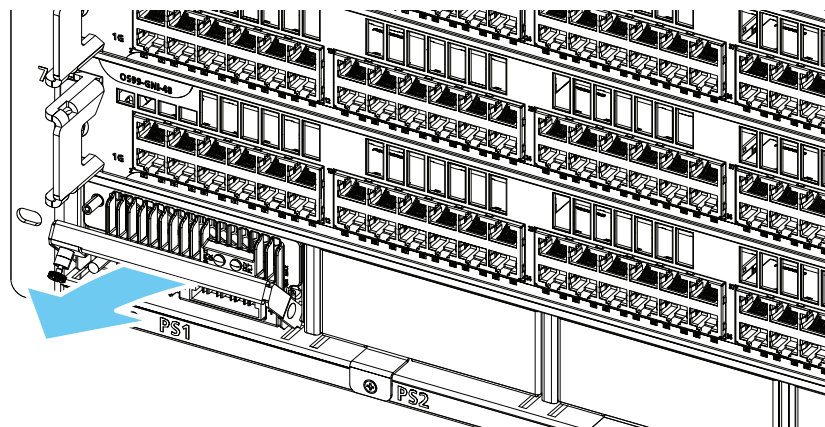

3. With one hand, grasp the handle at the front of the power supply and partially slide the power supply out of the slot. Place your other hand under the power supply casing to support its weight and remove the power supply from the chassis.

Note. Failure to support the chassis as it is being removed may cause the rear of the power supply casing to fall from the slot, resulting in damage to the equipment.

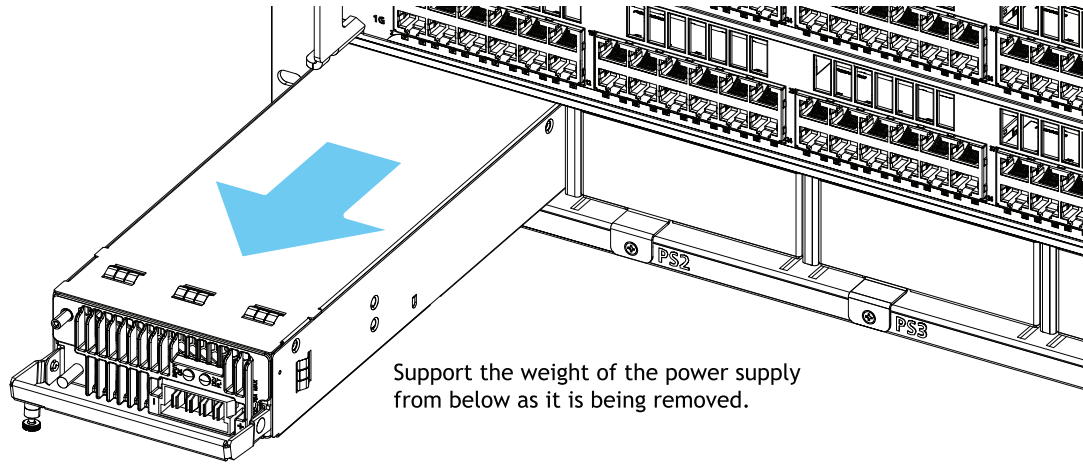

4. If the slot is to remain unused, install a blank cover panel over the space.

Removing Fan Trays

1. Loosen the thumb screw.

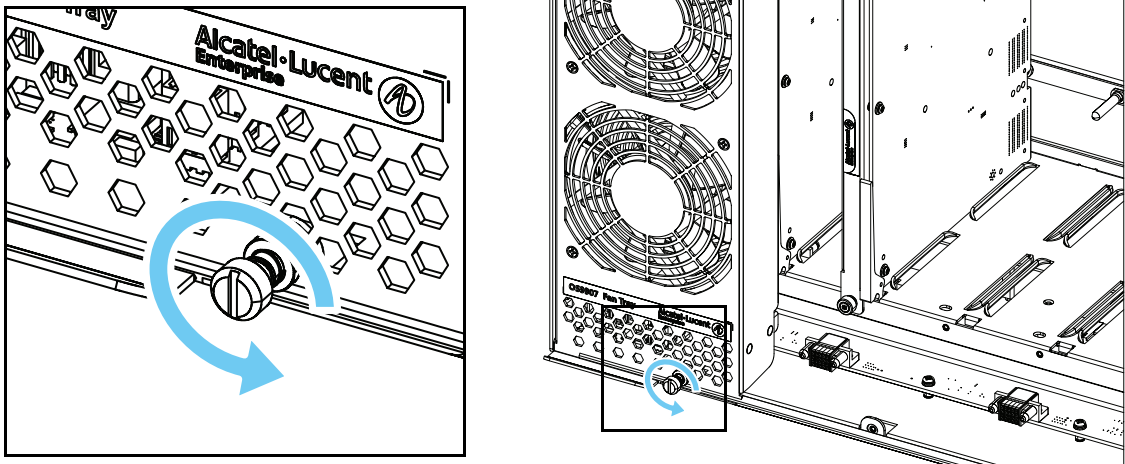

2. While holding the handles at the top and bottom of the fan tray, pull the bottom handle out until the bottom of the unit disengages from the chassis. Pull the unit out and down until the fan tray is clear of the tabs at the top of the fan tray slot.

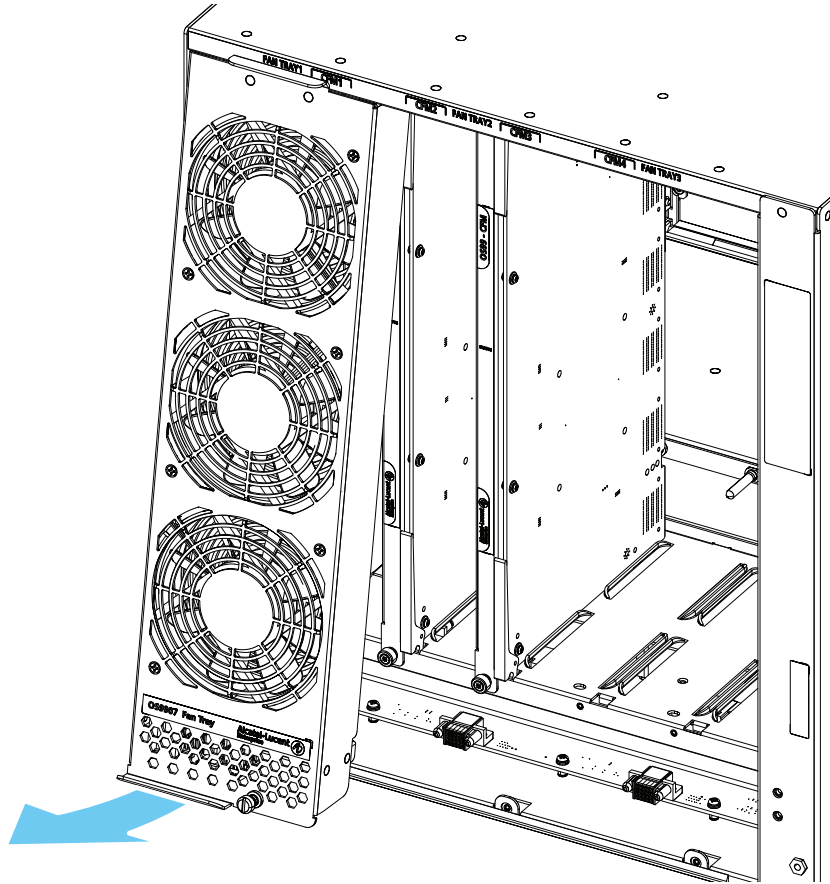

3. Three fan trays are required at all times. For switches currently operating, complete any maintenance and reinstall the fan tray as quickly as possible.

Removing Fabric Modules

To access CFM slots, be sure the fan trays covering the slots have been removed. (For information on removing fan trays, refer to [“Removing Fan Trays”](#) on page 4-53.)

1. Loosen the thumb screws at the top and bottom of the module, then pull the lock levers outward to release the CFM from the chassis.

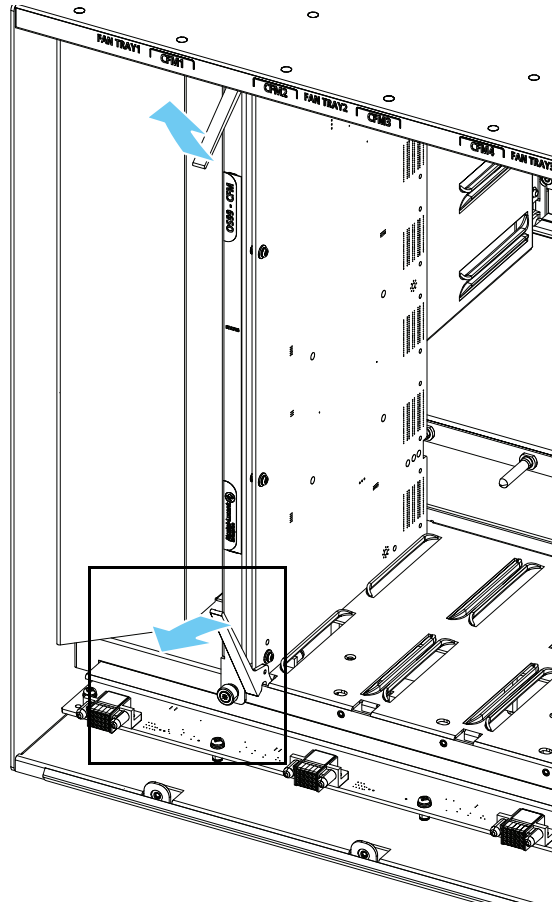
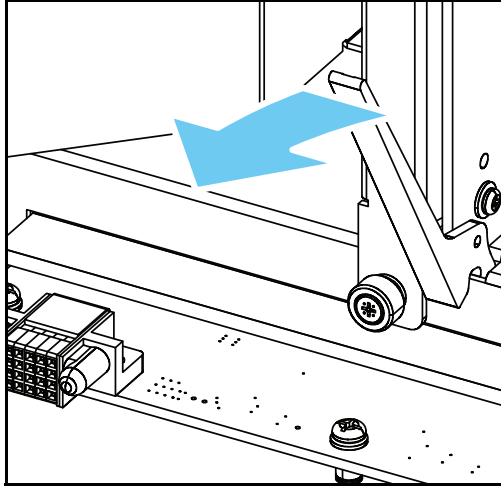

1. Grasp the CFM by the front panel and/or lock levers and slide the module out of the slot. Be sure to support the weight of the CFM as it is being removed to prevent the module from falling out of the chassis slot, which can result in damage to the equipment

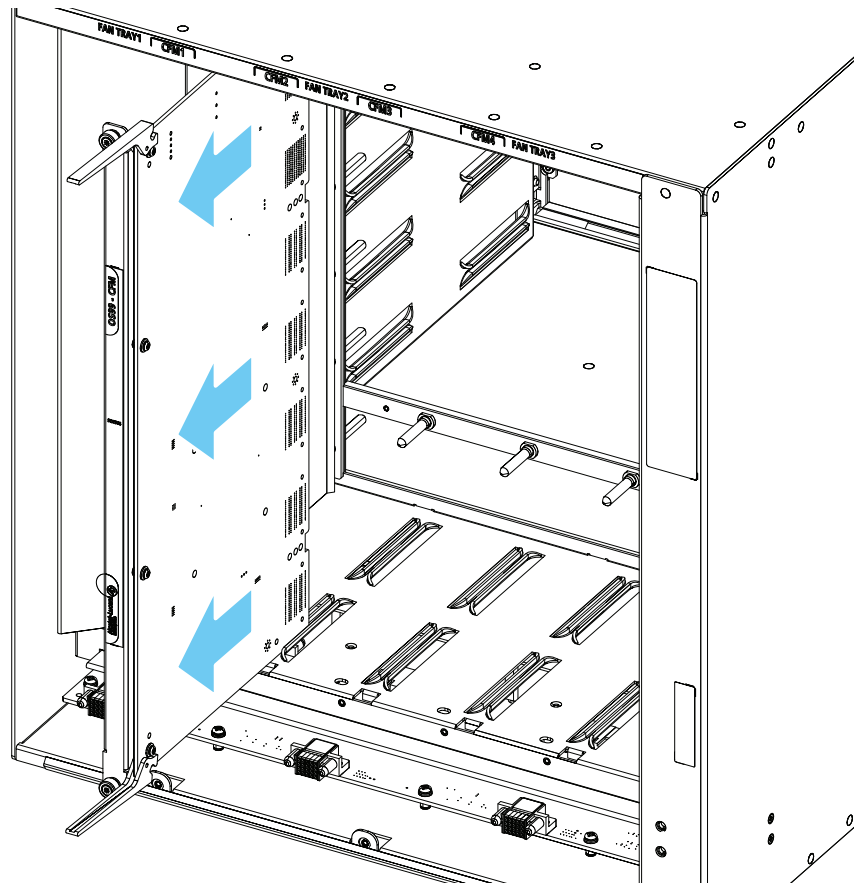

Removing Modules

1. Loosen the thumb screws at the left and right sides of the module, then press the lock levers outward to release the module from the chassis.

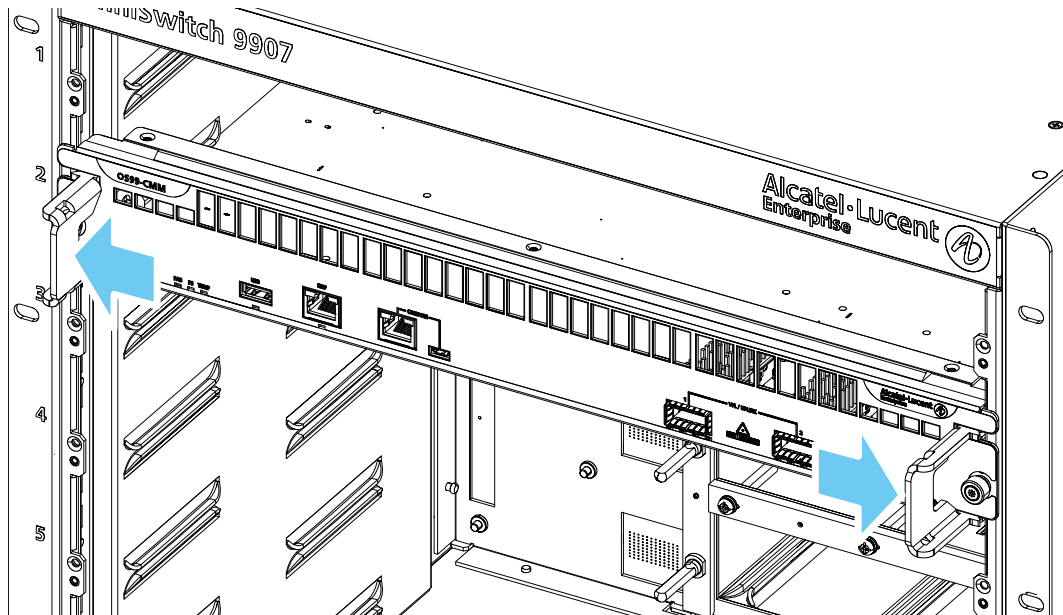

2. Grasp the module by the front panel and/or lock levers and slide the module out of the slot. Be sure to support the weight of the module as it is being removed to prevent the module from falling out of the chassis slot, which can result in damage to the equipment.

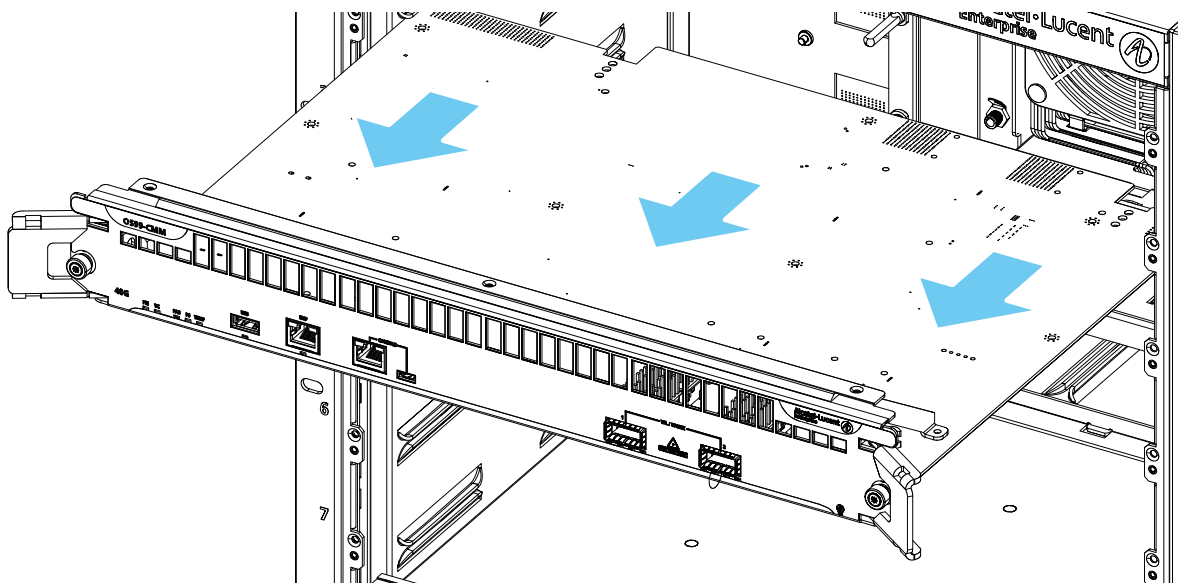

Hot Swapping

General Guidelines

- All component *removals* must have a 30 second interval before initiating another hot swap activity.
- All component *insertions* must have a five minute interval AND an LED state indicating that no errors have occurred before initiating another hot swap activity.
- Hot swapping CMMs, CFMs, or power supplies is supported ONLY if more than one of these components is installed. If only one CMM, CFM or power supply is installed and any of these components is removed, switch functions will be disrupted until a replacement is installed.
- Refer to product release notes for additional guidelines on hot swapping.

Hot Swapping Power Supplies

Mixing AC and DC power supplies is not supported. Mixing of Hi (240VAC) and Low (110VAC) input is not supported.

Hot Swapping CFMs

- Hot swap one CFM at a time.
- Ensure all fan trays are always inserted and operational.
- CFM hot swap should be completed within 120 seconds.

Hot Swapping NIs

- Disconnect all network cables from the module to be hot-swapped.
- Extract all transceivers from module to be hot-swapped, if applicable.
- Wait approximately 30 seconds before inserting a replacement module.
- Network Interface (NI) modules can only be hot swapped with like modules (refer to the table below).
- Follow any messages that may displayed.
- Re-insert all transceivers into the new module, if applicable.
- Re-connect all network cables.

A Regulatory Compliance and Safety Information

Compliance and Certifications

EMI/EMC - Commercial

- FCC 47 CFR Part 15 Class A
- ICES-003 Class A
- CE marking for European countries (Class A)
 - EMC Directive 89/336/EEC
 - EN55022:1998:2006 Class A
 - EN55024:1998:A1: 2001+A2:2003
 - EN61000-3-2
 - EN61000-3-3
 - EN61000-4-2
 - EN61000-4-3
 - EN61000-4-4
 - EN61000-4-5
 - EN61000-4-6
 - EN61000-4-8
 - EN61000-4-11
- CISPR22:1997 (Class A)
- VCCI (Class A)
- AS/NZS 3548 (Class A)
- IEEE 802.3 Hi-Pot requirement and 1.5 kV surge on data port for copper interfaces

Safety Agency Certifications

- US UL 60950
- IEC 60950-1:2001; all national deviations
- EN 60950-1: 2001; all deviations
- CAN/CSA-C22.2 No. 60950-1-03
- AS/NZ TS-001 and 60950:2000, Australia
- UL-AR, Argentina
- UL-GS Mark, Germany
- GOST, Russian Federation
- EN 60825-1 Laser
- EN 60825-2 Laser

- CDRH Laser

Note. For questions regarding these or other certifications, please contact Alcatel-Lucent Enterprise.

China RoHS: Hazardous Substance Table

部件名称 Part Name	有毒和危险品 Toxic and Hazardous Substances or Elements					
	铅 (Pb)	水银 (Hg)	镉 (Cd)	六价铬 (Cr(VI))	多溴化苯 (PBB)	多溴化二苯醚 (PBDE)
电路模块 (Circuit Boards)	X	○	○	○	○	○
电缆及电缆组件 (Cables & Cable Accessories)	X	○	○	○	○	○
金属部件 (Metal Parts)	X	○	○	○	○	○
塑料和聚合物部件 (Plastic and Polymeric parts)	○	○	○	○	○	○
可插拔模块 (Pluggable modules)	X	○	○	○	○	○
电池 (Batteries)	○	○	○	○	○	○

本表格依据 SJ/T 11364 的规定编制

○ = 表示该有害物质在该部件所有均质材料中的含量均在 GB/T 26572 规定的限量要求以下 (indicates that the content of the toxic and hazardous substance in all the Homogeneous Materials of the part is below the concentration limit requirement as described in GB/T 26572).

X = 表示该有害物质至少在该部件的某一均质材料中的含量超出 GB/T 26572 规定的限量要求 (indicates that the content of the toxic and hazardous substance in at least one Homogeneous Material of the part exceeds the concentration limit requirement as described in GB/T 26572).

Taiwan RoHS: Hazardous Substance Table

设备名称：交換機和路由器產品						
单位	受限物质及其化学符号					
	铅 (Pb)	汞 (Hg)	镉 (Cd)	六价铬 (Cr+6)	多溴联苯 (PBB)	多溴二苯醚 (PBDE)
電路板 (Circuit Boards)	-	○	○	○	○	○
電纜及電纜配件 (Cables & Cable Accessories)	-	○	○	○	○	○
金屬部件 (Metal Parts)	-	○	○	○	○	○
塑料和聚合物部件 (Plastic and Polymeric Parts)	○	○	○	○	○	○
可插拔模塊 (Pluggable modules)	-	○	○	○	○	○
電池 (Batteries)	○	○	○	○	○	○
注 1: “○” 表示该项受限物质的含量百分比未超过百分比含量基准值。 注 2: “-” 表示该项受限物质为排除项目。						

California Proposition 65 Warning

WARNING: This product can expose you to chemicals including Pb and Pb compounds, which is known to the State of California to cause cancer and birth defects or other reproductive harm. For more information go to www.P65Warnings.ca.gov.

Products are packaged using one or more of the following packaging materials:

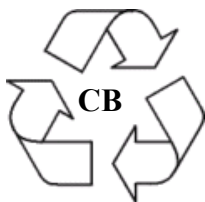

Corrugated Cardboard

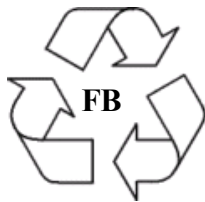

Corrugated Fiberboard



Low-Density Polyethylene

Waste Electrical and Electronic Equipment (WEEE) Statement

The product at end of life is subject to separate collection and treatment in the EU Member States, Norway and Switzerland, and is therefore marked with the symbol:

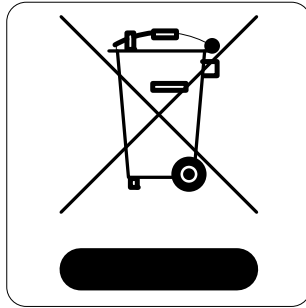

Treatment applied at end of life of the product in these countries shall comply with the applicable national laws implementing directive 2002/96EC on Waste Electrical and Electronic Equipment (WEEE).

FCC Class A, Part 15

This equipment has been tested and found to comply with the limits for Class A digital device pursuant to Part 15 of the FCC Rules. These limits are designed to provide reasonable protection against harmful interference when the equipment is operated in a commercial environment. This equipment generates, uses, and can radiate radio frequency energy and, if not installed and used in accordance with the instructions in this guide, may cause interference to radio communications. Operation of this equipment in a residential area is likely to cause interference, in which case the user will be required to correct the interference at his own expense.

The user is cautioned that changes and modifications made to the equipment without approval of the manufacturer could void the user's authority to operate this equipment. It is suggested that the user use only shielded and grounded cables to ensure compliance with FCC Rules.

If this equipment does cause interference to radio or television reception, the user is encouraged to try to correct the interference by one or more of the following measures:

- Reorient the receiving antenna.
- Relocate the equipment with respect to the receiver.
- Move the equipment away from the receiver.
- Plug the equipment into a different outlet so that equipment and receiver are on different branch circuits.

If necessary, the user should consult the dealer or an experienced radio/television technician for additional suggestions.

Canada Class A Statement

This equipment does not exceed Class A limits per radio noise emissions for digital apparatus, set out in the Radio Interference Regulation of the Canadian Department of Communications.

Avis de conformité aux normes du ministère des Communications du Canada

Cet équipement ne dépasse pas les limites de Classe A d'émission de bruits radioélectriques pour les appareils numériques, telles que prescrites par le Règlement sur le brouillage radioélectrique établi par le ministère des Communications du Canada.

JATE

This equipment meets the requirements of the Japan Approvals Institute of Telecommunications Equipment (JATE).

CISPR22 Class A Warning

This is a Class A product. In a domestic environment, this product may cause radio interference. Under such circumstances, the user may be requested to take appropriate countermeasures.

Korea Emissions Statement

A 급 기기 (업무용 방송통신 기자재)
이 기기는 업무용 (A 급) 전자파적합기기로서 판매자 또는 사용자는 이 점을 주의하시기 바라며, 가정외의 지역에서 사용하는 것을 목적으로 합니다.

Class A Equipment (Business equipment)
This equipment is registered for Electromagnetic Conformity Registration as business equipment (A), not home equipment. Sellers or users are required to take caution in this regard.

VCCI

This is a Class A product based on the standard of the Voluntary Control Council for Interference by Information Technology Equipment (VCCI). If this equipment is used in a domestic environment, radio disturbance may arise. When such trouble occurs, the user may be required to take corrective actions.

この装置は、情報処理装置等電波障害自主規制協議会（VCCI）の基準に基づくクラス A 情報技術装置です。この装置を家庭環境で使用すると電波妨害を引き起こすことがあります。この場合には使用者が適切な対策を講ずるよう要求されることがあります。

Class A Warning for Taiwan (BSMI) and Other Chinese Markets

Warning: To avoid electromagnetic interference, this product should not be installed or used in residential environments.

警告：為避免電磁干擾，本產品不應安裝或使用於住宅環境

Translated Safety Warnings

Chassis Lifting Warning

Two people are required when lifting the chassis. Due to its weight, lifting the chassis unassisted can cause personal injury. Also be sure to bend your knees and keep your back straight when assisting with the lifting of the chassis.

Français: Le châssis doit être soulevé par deux personnes au minimum. Pour éviter tout risque d'accident, maintenez le dos droit et poussez sur vos jambes. Ne soulevez pas l'unité avec votre dos.

Deutsch: Sicherheitshinweise Hinweise zum Anheben des Chassis:

Zum Anheben des Chassis werden zwei Personen benötigt. Aufgrund des Gewichts kann das Anheben ohne Unterstützung zu Personenschäden führen. Heben Sie das Chassis aus den Knien und halten Sie den Rücken gerade wenn Sie beim Anheben des Chassis assistieren.

Español: Se requieren dos personas para elevar el chasis. Para evitar lesiones, mantenga su espalda en posición recta y levante con sus piernas, no con su espalda.

Electrical Storm Warning

To avoid a shock hazard, do not connect or disconnect any cables or perform installation, maintenance, or reconfiguration of this product during an electrical storm.

Français: Ne pas travailler sur le système ni brancher ou débrancher les câbles pendant un orage.

Deutsch: Hinweise bei Unwetter:

Um elektrische Schläge zu vermeiden dürfen während eines Gewitters and diesem Gerät keine Kabel angeschlossen oder gelöst werden, sowie keinerlei Installationen, Wartungen oder Konfigurationen vorgenommen werden.

Español: Para evitar peligro de descargas, no conecte o desconecte ningún cable, ni realice ninguna instalación, mantenimiento o reconfiguración de este producto durante una tormenta eléctrica.

Installation Warning

Only personnel knowledgeable in basic electrical and mechanical procedures should install or maintain this equipment.

Français: Toute installation ou remplacement de l'appareil doit être réalisée par du personnel qualifié et compétent.

Deutsch: Installationshinweise: Dieses Gerät soll nur von Personal installiert oder gewartet werden, welches in elektrischen und mechanischen Grundlagen ausgebildet ist.

Español: Estos equipos deben ser instalados y atendidos exclusivamente por personal adecuadamente formado y capacitado en técnicas eléctricas y mecánicas.

Invisible Laser Radiation Warning

Lasers emit invisible radiation from the aperture opening when no fiber-optic cable is connected. When removing cables do not stare into the open apertures. In addition, install protective aperture covers to fiber with no cable connected.

Français: Des radiations invisibles à l'oeil nu pouvant traverser l'ouverture du port lorsque aucun câble en fibre optique n'y est connecté, il est recommandé de ne pas regarder fixement l'intérieur de ces ouvertures. Installez les caches connecteurs prévus à cet effet.

Deutsch: Hinweise zur unsichtbaren Laserstrahlung:

Die Laser strahlen an der Blendenöffnung unsichtbares Licht ab, wenn keine Glasfaserkabel angeschlossen sind. Blicken Sie nicht in die Öffnungen und installieren Sie unverzüglich die Abdeckungen über den Glasfaseranschlüssen.

Español: Debido a que la apertura del puerto puede emitir radiación invisible cuando no hay un cable de fibra conectado, procurar no mirar directamente a las aperturas para no exponerse a la radiación.

Power Disconnection Warning

Your switch is equipped with multiple power supplies. To reduce the risk of electrical shock, be sure to disconnect all power connections before servicing or moving the unit.

Français: Il se peut que cette unité soit équipée de plusieurs raccordements d'alimentation. Pour supprimer tout courant électrique de l'unité, tous les cordons d'alimentation doivent être débranchés.

Deutsch: Hinweise zur Spannungsfreischaltung:

Ihr Gerät ist mit mehreren Netzteilen ausgerüstet. Um die Gefahr des elektrischen Schlages zu verringern, stellen sie sicher, daß alle Netzverbindungen getrennt sind bevor das Gerät gewartet oder bewegt wird.

Español: Antes de empezar a trabajar con un sistema, asegúrese que el interruptor está cerrado y el cable eléctrico desconectado.

Proper Earthing Requirement Warning

To avoid shock hazard:

- The power cord must be connected to a properly wired and earth receptacle.
- Any equipment to which this product will attached must also be connected to properly wired receptacles.
- Use 22AWG solid copper conductor for ground leads connecting the frame to ground and DC return.

- Cleaning and dressing of grounding points during installation is strongly recommended. Also, do not forget the antioxidant.
- To ground the equipment properly, connect a Panduit Corporation UL listed Lug, P/N: LCD8-10AL to the two threaded holes located on the rear using 8AWG copper conductors. Use Panduit Corporation, P/N: CT-940CH for crimping. Torque to between 30-60 inch pounds.

Français: Pour éviter tout risque de choc électrique:

- Ne jamais rendre inopérant le conducteur de masse ni utiliser l'équipement sans un conducteur de masse adéquatement installé.
- En cas de doute sur la mise à la masse appropriée disponible, s'adresser à l'organisme responsable de la sécurité électrique ou à un électricien.

Deutsch: Hinweise zur geforderten Erdung des Gerätes: Aus Sicherheitsgründen:

- Darf das Netzkabel nur an eine Schutzkontaktsteckdose angeschlossen werden.
- Dürfen für den Anschluß anderer Geräte, welche mit diesem Gerät verbunden sind, auch nur Schutzkontaktsteckdosen verwendet werden.

Español: Para evitar peligro de descargas:

- Para evitar peligro de descargas asegúrese de que el cable de alimentación está conectado a una toma de alimentación adecuadamente cableada y con toma de tierra.
- Cualquier otro equipo a cual se conecte este producto también debe estar conectado a tomas de alimentación adecuadamente cableadas.

Read Important Safety Information Warning

This guide contains important safety information about which you should be aware when working with hardware components in this system. You should read this guide before installing, using, or servicing this equipment.

Français: Avant de brancher le système sur la source d'alimentation, consultez les directives d'installation disponibles dans ceci guide.

Deutsch: Bitte lesen - Sicherheitshinweise:

Diese Anleitung enthält wichtige Sicherheitsinformationen, über die sie sich beim Arbeiten mit den Hardwareeinheiten bewußt sein sollten. Sie sollten diese Hinweise lesen, bevor sie installieren, reparieren oder die Anlage verwenden.

Español: Esto guide contiene información importante de seguridad sobre la cual usted debe estar enterado al trabajar con los componentes de dotación física en este sistema. Usted debe leer esta guía antes de instalar, usar o mantener este equipo.

Restricted Access Location Warning

This equipment should be installed in a location that restricts access. A restricted access location is one where access is secure and limited to service personnel who have a special key, or other means of security.

Français: Le matériel doit être installé dans un local avec accès limité ou seules les personnes habilitées peuvent entrer.

Deutsch: Hinweis zu Umgebungen mit beschränktem Zutritt:

Die Anlage sollte an einem Standort mit beschränktem Zutritt installiert sein. Ein Standort mit beschränktem Zutritt stellt sicher, daß dort nur Servicepersonal mit Hilfe eines Schlüssels oder eines anderen Sicherheitssystems Zugang hat.

Español: Este equipo se debe instalar en un sitio con acceso restringido. Un sitio con el acceso restringido es uno seguro y con acceso limitado al personal de servicio que tiene una clave especial u otros medios de seguridad.

Wrist Strap Warning

Because electrostatic discharge (ESD) can damage switch components, you must ground yourself properly before continuing with the hardware installation. For this purpose, Alcatel-Lucent Enterprise provides a grounding wrist strap and a grounding lug located near the top-right of the chassis. For the grounding wrist strap to be effective in eliminating ESD, the power supplies must be installed in the chassis and plugged into grounded AC outlets.

Français: L'électricité statique (ESD) peut endommager les composants du commutateur. Pour cette raison Alcatel-Lucent Enterprise joint à l'envoi du châssis un bracelet antistatique à brancher sur la prise mise à la terre située en bas à droite du commutateur. Vous devrez mettre ce bracelet avant toute intervention hardware.

Deutsch: Hinweise zur ESD (Elektrostatischen Aufladung):

Weil elektrostatische Aufladung (ESD) Teile der Anlage beschädigen könnten, müssen sie sich selbst erden, bevor sie mit der Hardware Installation beginnen. Zu diesem Zweck stellt Alcatel-Lucent Enterprise ein Erdungsarmband und eine Erdungsöse an der oberen rechten Seite des Chassis zur Verfügung. Um eine sichere Erdungsfunktion des Erdungsarmbandes sicherzustellen, müssen die Netzteile installiert und mit dem Schutzleiter des Versorgungsstromkreises verbunden sein.

Español: La descarga electrostática (ESD) puede dañar componentes electrónicos. Usted debe asegurarse que está en contacto con tierra antes de hacer la instalación del equipo. Con este fin, Alcatel-Lucent Enterprise proporciona una pulsera de muñeca para conectar al chasis en la toma de tierra situada en la parte superior derecha del chasis. Para que la correa de muñeca sea eficaz en la eliminación de ESD, las fuentes de alimentación deben estar instaladas en el chasis y conectadas a enchufes CA con tierra adecuada.

Instrucciones de seguridad en español

Advertencia sobre el levantamiento del chasis

Se requieren dos personas para levantar el chasis. Debido a su peso, la elevación del chasis sin ayuda puede causar daños corporales. También es seguro doblar sus rodillas y guardar su espalda derecho al ayudar a levantar el chasis.

Advertencia de las tapaderas en blanco

Porque regulan la circulación de aire y ayudan a proteger componentes internos del chasis, las tapaderas en blanco deben seguir instaladas en las ranuras vacías del módulo y la fuente de alimentación siempre.

Advertencia en caso de tormenta eléctrica

Para evitar peligro de descargas, no conecte o desconecte ningún cable, ni realice ninguna instalación, mantenimiento o reconfiguración de este producto durante una tormenta eléctrica.

Advertencia de instalación

Solamente el personal bien informado en procedimientos eléctricos y mecánicos básicos debe instalar o mantener este equipo.

Advertencia de radiación láser invisible

Los lasers emiten radiación invisible de la apertura abierta cuando no se conecta ningún cable de fibra óptica. Al quitar los cables no mire fijamente en las aberturas abiertas. Además, instale las cubiertas protectoras de la apertura a las salidas de la fibra sin el cable conectado.

Advertencia de la batería de litio

Hay un peligro de la explosión si la batería del litio en su chasis se substituye incorrectamente. Substituya la batería solamente por el mismo o el equivalente de tipo de batería recomendado por el fabricante. Deseche las baterías usadas según las instrucciones del fabricante. Las instrucciones del fabricante son como sigue: Devuelva el módulo con la batería del litio a Alcatel-Lucent. La batería del litio será substituida en la fábrica de Alcatel-Lucent.

Advertencia sobre la tensión de operación

Para reducir el riesgo del choque eléctrico, matenga sus manos y dedos fuera de la fuente de alimentación y no toque la placa madre mientras que el interruptor está funcionando.

Advertencia sobre la desconexión de la fuente

Su interruptor esta equipado por fuentes de alimentación múltiples. Para reducir el riesgo de choque eléctrico, asegúrese desconectar todas las conexiones de alimentación antes de mantener o de mover la unidad.

